

DataPanel GmbH

Blumenstr. 22/1
 D-71522 Backnang
 Tel. +49 7191 90436911



Firma / Kunde
 Company / customer ...

Projektbeschreibung
 Project description Makro Dokumentation EPLAN V2.7 - V1.2
 macro Documentation EPLAN V2.7 - V1.2

Zeichnungsnummer
 Job number

Kommission
 Commission ANLAGE 1 - BEISPIEL

Hersteller / Lieferant
 Manufacturer / supplier DataPanel GmbH

Pfad
 Path ...\\Projekte\DataPanel\...

Projektname
 Project name DAPA_MUSTERPROJEKT_EPL27_V1.2

Fabrikat
 Make DATA PANEL

Typ
 Type Beschreibung Makros
 description Macros

Installationsort
 Place of installation

Projektverantwortlicher
 Responsible for project Krautter/IAW

Erstellt am
 Created on 31.01.2022

Bearbeitet am
 Edit date 07.02.2022 von (Kürzel) WR
 by (short name)

Anzahl der Seiten
 Number of pages 30

Eigentum und Urheberrecht Fa. Data Panel - Schutzvermerk nach ISO 16016 beachten all rights and copyright Data Panel Corp. - observe protective note according to ISO 16016

Datum	31.01.2022	ANLAGE 1 - BEISPIEL		Titel- / Deckblatt Title page / cover sheet	= DOC	
Bearb.	WR	Makro Dokumentation EPLAN V2.7 - V1.2			DAPA_MUSTERPROJEKT_EPL27_V1.2	+
Gepr		macro Documentation EPLAN V2.7 - V1.2				Blatt 1
Änderung	Datum	Name	Urspr	Ersatz von	Ersetzt durch	Blatt 30

Inhaltsverzeichnis

Table of contents

Spalte X: eine automatisch erzeugte Seite wurde manuell nachbearbeitet
 Column X: An automatically generated page was edited

F06_001DPa1

Seite Page	Seitenbeschreibung Page description	Seitenzusatzfeld supplementary page field	Datum Date	Bearbeiter Edited by	X
=DOC/1	Titel- / Deckblatt Title page / cover sheet		31.01.2022	WR	
=DOC/2	Inhaltsverzeichnis Table of contents		07.02.2022	WR	
=UNIT1+MA&EFA00/1	Gesamtübersicht CAN-Verteiler complete overview CAN-distributor		04.02.2022	WR	
=UNIT1+MA&EFA00/2	Gesamtübersicht Verteiler 1 - OUT complete overview distributor 1 - OUT		04.02.2022	WR	
=UNIT1+MA&EFA00/3	Gesamtübersicht Verteiler 2 - IN/OUT complete overview distributor 2 - IN/OUT		04.02.2022	WR	
=UNIT1+MA&EFA00/4	Gesamtübersicht Verteiler 3 - IN complete overview distributor 3 - IN		04.02.2022	WR	
=UNIT1+MA&EFA00/5	Gesamtübersicht Verteiler 4 - OUT PWM(i) complete overview distributor 4 - OUT PWM(i)		04.02.2022	WR	
=UNIT1+MA&EFA00/6	Gesamtübersicht Verteiler 5 - PVE complete overview distributor 5 - PVE		04.02.2022	WR	
=UNIT1+MA&EFA01/1	SPS-Diagramm : =UNIT1+MA-2XG1 - =UNIT1+MA-2XG1 PLC diagram : =UNIT1+MA-2XG1 - =UNIT1+MA-2XG1		04.02.2022	WR	
=UNIT1+MA&EFA01/2	SPS-Diagramm : =UNIT1+MA-2XG2 - =UNIT1+MA-2XG2 PLC diagram : =UNIT1+MA-2XG2 - =UNIT1+MA-2XG2		04.02.2022	WR	
=UNIT1+MA&EFA01/3	SPS-Diagramm : =UNIT1+MA-2XG3 - =UNIT1+MA-2XG3 PLC diagram : =UNIT1+MA-2XG3 - =UNIT1+MA-2XG3		04.02.2022	WR	
=UNIT1+MA&EFA01/4	SPS-Diagramm : =UNIT1+MA-3XG1 - =UNIT1+MA-3XG1 PLC diagram : =UNIT1+MA-3XG1 - =UNIT1+MA-3XG1		04.02.2022	WR	
=UNIT1+MA&EFA01/5	SPS-Diagramm : =UNIT1+MA-11XG1 - =UNIT1+MA-11XG1 PLC diagram : =UNIT1+MA-11XG1 - =UNIT1+MA-11XG1		04.02.2022	WR	
=UNIT1+MA&EFS/1	Stromlaufplan CAN-Verteiler wiring diagram CAN-distributor		04.02.2022	WR	
=UNIT1+MA&EFS/2	Stromlaufplan Verteiler 1 - 3 wiring diagram distributor 1 - 3		04.02.2022	WR	
=UNIT1+MA&EFS/3	Stromlaufplan Verteiler 4 wiring diagram distributor 4		04.02.2022	WR	
=UNIT1+MA&EFS/4	Stromlaufplan Power Splitter wiring diagram Power Splitter		04.02.2022	WR	
=UNIT1+MA&EFS/4a	Stromlaufplan Versorgung Verteiler 1 - 4 wiring diagram supply distributor 1 - 4		04.02.2022	WR	
=UNIT1+MA&EFS/4b	Stromlaufplan Versorgung Verteiler 1 - 4 wiring diagram supply distributor 1 - 4		04.02.2022	WR	
=UNIT1+MA&EFS/5	Stromlaufplan OUT Verteiler 1 wiring diagram OUT distributor 1		04.02.2022	WR	
=UNIT1+MA&EFS/6	Stromlaufplan OUT Verteiler 2 wiring diagram OUT distributor 2		04.02.2022	WR	
=UNIT1+MA&EFS/7	Stromlaufplan IN Verteiler 2 wiring diagram IN distributor 2		04.02.2022	WR	
=UNIT1+MA&EFS/8	Stromlaufplan IN Verteiler 3 wiring diagram IN distributor 3		04.02.2022	WR	
=UNIT1+MA&EFS/9	Stromlaufplan IN Verteiler 3 wiring diagram IN distributor 3		04.02.2022	WR	
=UNIT1+MA&EFS/10	Stromlaufplan OUT PWM(i) Verteiler 4} !! XXXXXXXXXXXX !!		07.02.2022	WR	
=UNIT1+MA&EFS/11	Stromlaufplan Verteiler 5 - PVE wiring diagram distributor 5 - PVE		04.02.2022	WR	
=UNIT1+MA&EFS/12	Stromlaufplan OUT/IN - PVE wiring diagram OUT/IN - PVE		04.02.2022	WR	
=UNIT1+MA&EFS/13	Stromlaufplan OUT/IN - PVE wiring diagram OUT/IN - PVE		04.02.2022	WR	
=UNIT1+MA&ELU/1	Aufbauplan Verteiler 3D - (Modell-Ansicht) layout diagram distributor 3D - (Model view)		07.02.2022	WR	
=UNIT1+MA&EPC/1	Stückliste Bill of materials		04.02.2022	WR	

Eigentum und Urheberrecht Fa. Data Panel - Schutzvermerk nach ISO 16016 beachten all rights and copyright Data Panel Corp. - observe protective note according to ISO 16016

=UNIT1+MA&EFA00/1

1

Datum	07.02.2022	ANLAGE 1 - BEISPIEL Makro Dokumentation EPLAN V2.7 - V1.2 macro Documentation EPLAN V2.7 - V1.2		Inhaltsverzeichnis Table of contents	= DOC +	DAPA_MUSTERPROJEKT_EPL27_V1.2	Blatt	2
Bearb.	WR						Blatt	30
Gepr								
Änderung	Datum	Name	Urspr	Ersatz von	Ersetzt durch			

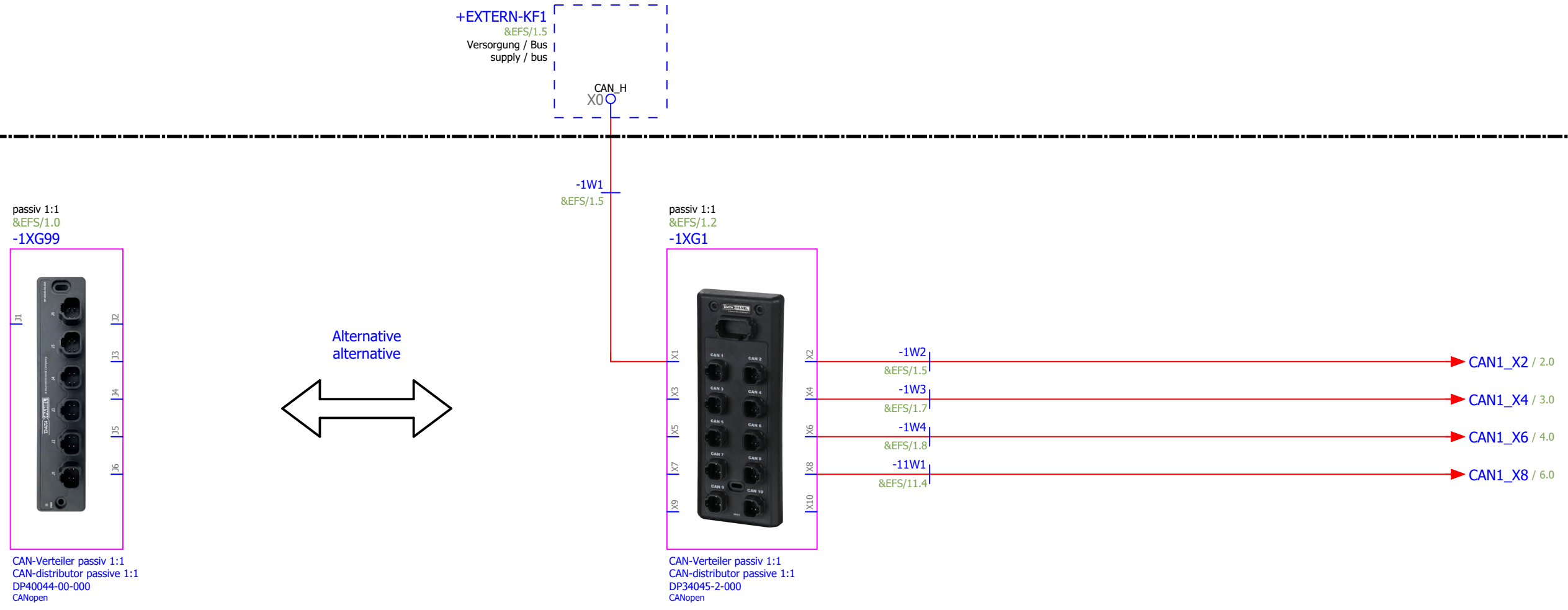

=DOC+&/2

		Datum	04.02.2022	ANLAGE 1 - BEISPIEL		= UNIT1	
		Bearb.	WR	Makro Dokumentation EPLAN V2.7 - V1.2		+ MA	
		Gepr		macro Documentation EPLAN V2.7 - V1.2			
Änderung	Datum	Name	Urspr	Ersatz von	Ersetzt durch	DAPA_MUSTERPROJEKT_EPL27_V1.2	Blatt 1
							Blatt 30

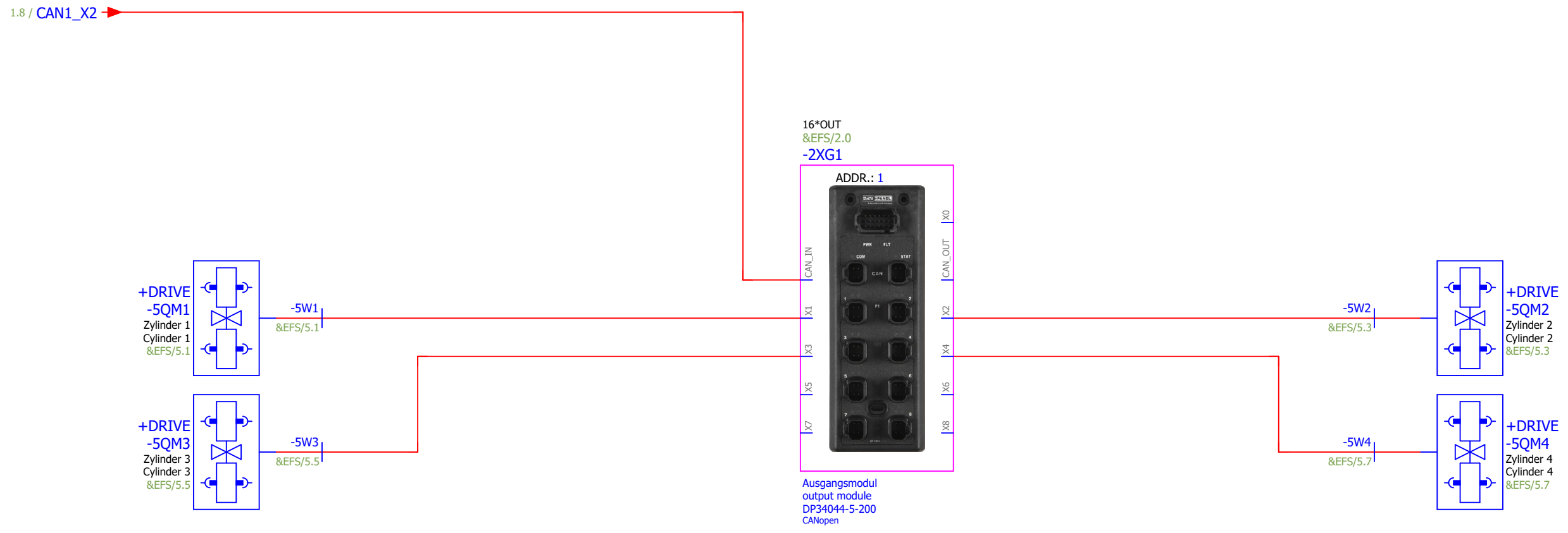

16*OUT
&EFS/2.0
-2XG1

ADDR.: 1

Ausgangsmodule
output module
DP34044-5-200
CANopen

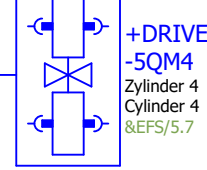
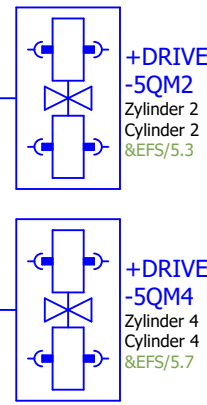
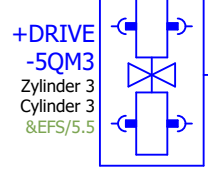
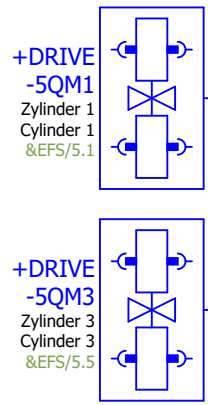

			Datum	04.02.2022	ANLAGE 1 - BEISPIEL		= UNIT1	
			Bearb.	WR	Makro Dokumentation EPLAN V2.7 - V1.2		+ MA	
			Gepr		macro Documentation EPLAN V2.7 - V1.2			
Änderung	Datum	Name	Urspr		Ersatz von	Ersetzt durch	DAPA_MUSTERPROJEKT_EPL27_V1.2	
							Blatt	2
							Blatt	30

1.8 / CAN1_X4

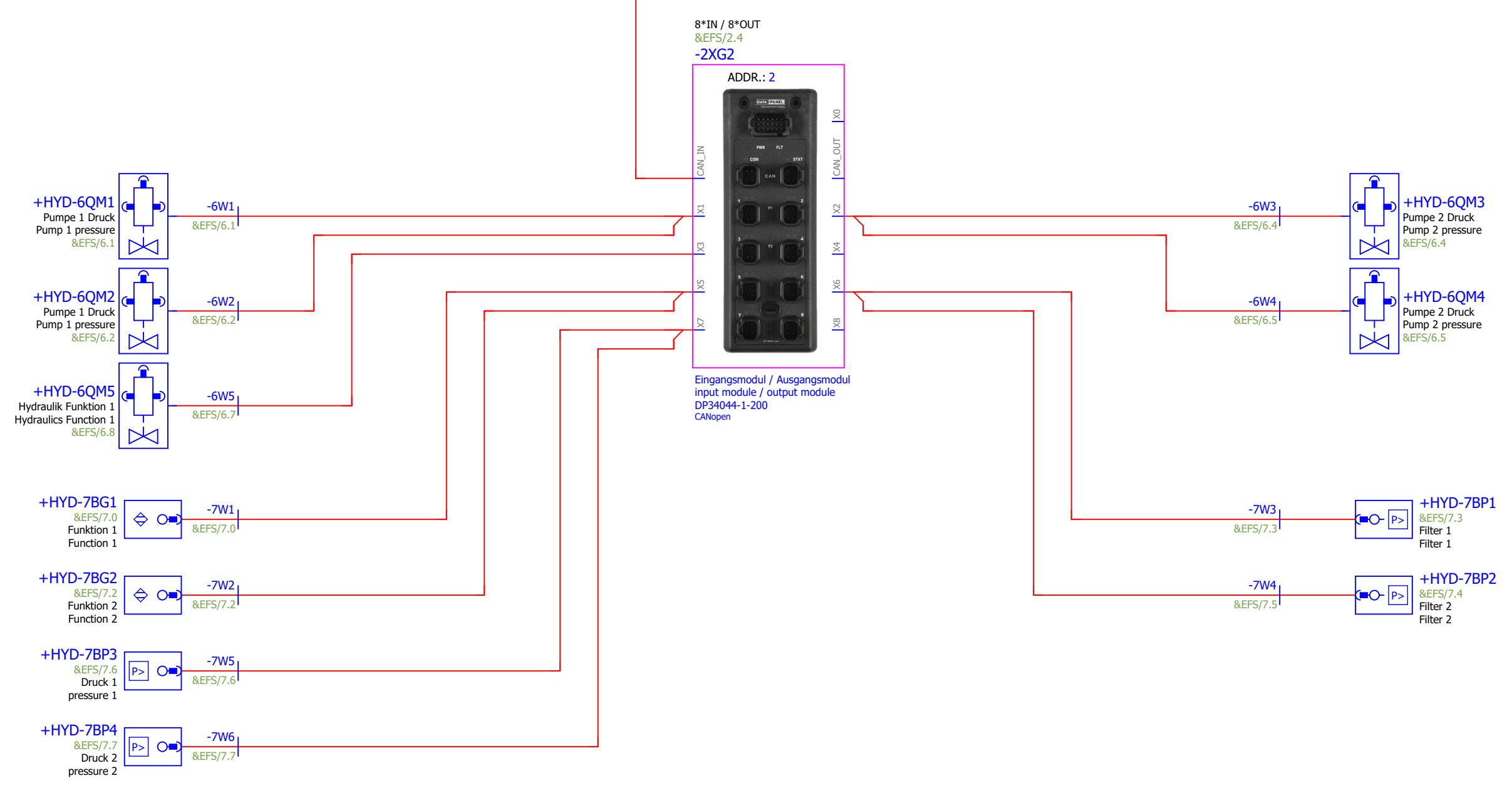

		Datum	04.02.2022	ANLAGE 1 - BEISPIEL		Gesamtübersicht Verteiler 2 - IN/OUT		= UNIT1	
		Bearb.	WR	Makro Dokumentation EPLAN V2.7 - V1.2		complete overview distributor 2 - IN/OUT		+ MA	
		Gepr		macro Documentation EPLAN V2.7 - V1.2				DAPA_MUSTERPROJEKT_EPL27_V1.2	
Änderung	Datum	Name	Urspr	Ersatz von	Ersetzt durch			Blatt	3
								Blatt	30



1.8 / CAN1_X6

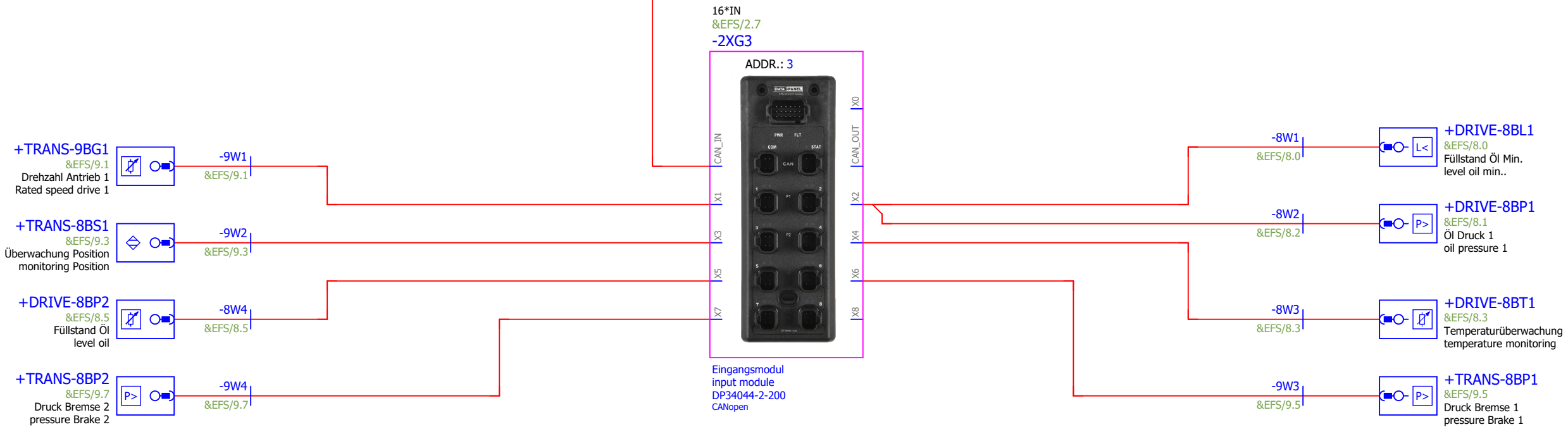

			Datum	04.02.2022	ANLAGE 1 - BEISPIEL		= UNIT1	
			Bearb.	WR	Makro Dokumentation EPLAN V2.7 - V1.2		+ MA	
			Gepr		macro Documentation EPLAN V2.7 - V1.2			
Änderung	Datum	Name	Urspr		Ersatz von	Ersetzt durch	DAPA_MUSTERPROJEKT_EPL27_V1.2	
							Blatt 4	
							Blatt 30	



Gesamtübersicht Verteiler 3 - IN
complete overview distributor 3 - IN

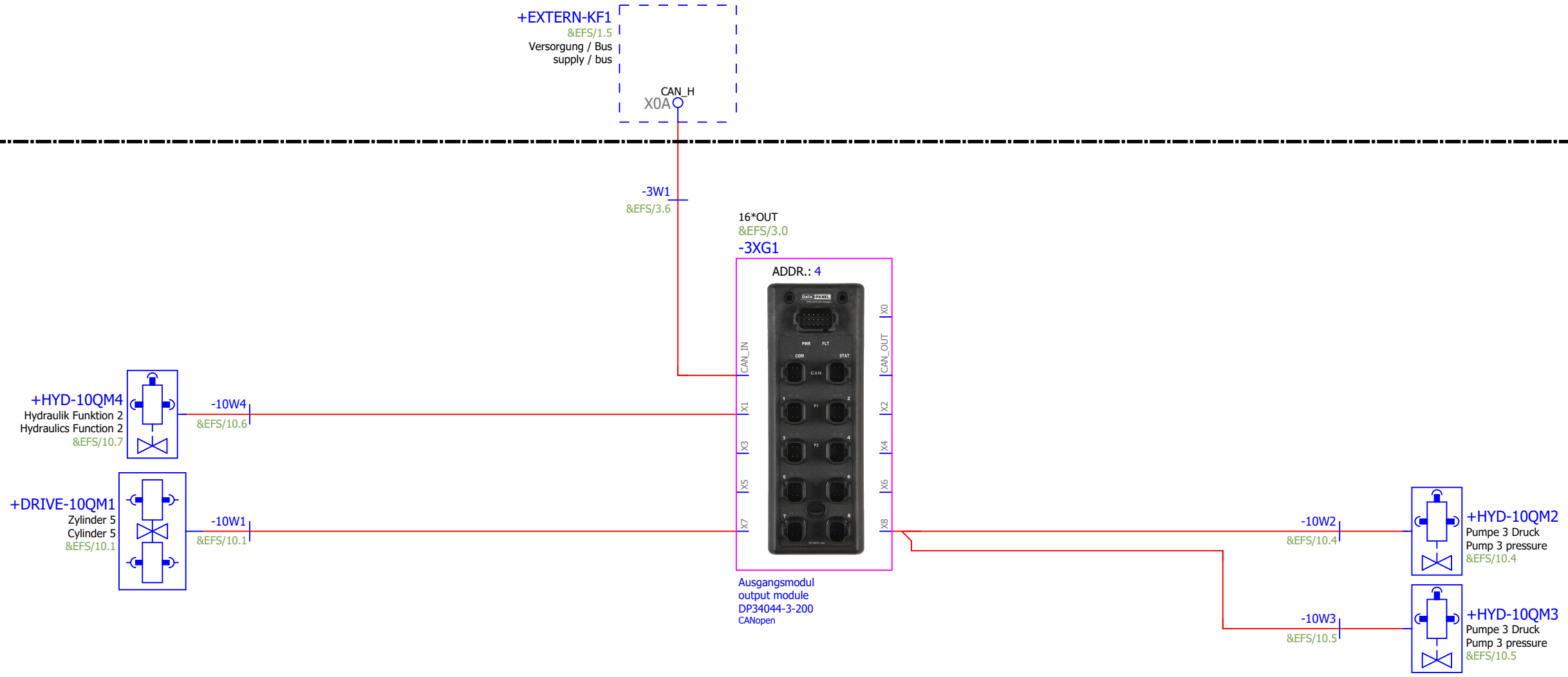

		Datum	04.02.2022	ANLAGE 1 - BEISPIEL				Gesamtübersicht Verteiler 4 - OUT PWM(i)		= UNIT1			
		Bearb.	WR	Makro Dokumentation EPLAN V2.7 - V1.2				complete overview distributor 4 - OUT PWM(i)				+ MA	
		Gepr		macro Documentation EPLAN V2.7 - V1.2						DAPA_MUSTERPROJEKT_EPL27_V1.2		Blatt 5	
Änderung	Datum	Name	Urspr	Ersatz von	Ersetzt durch					Blatt 30			

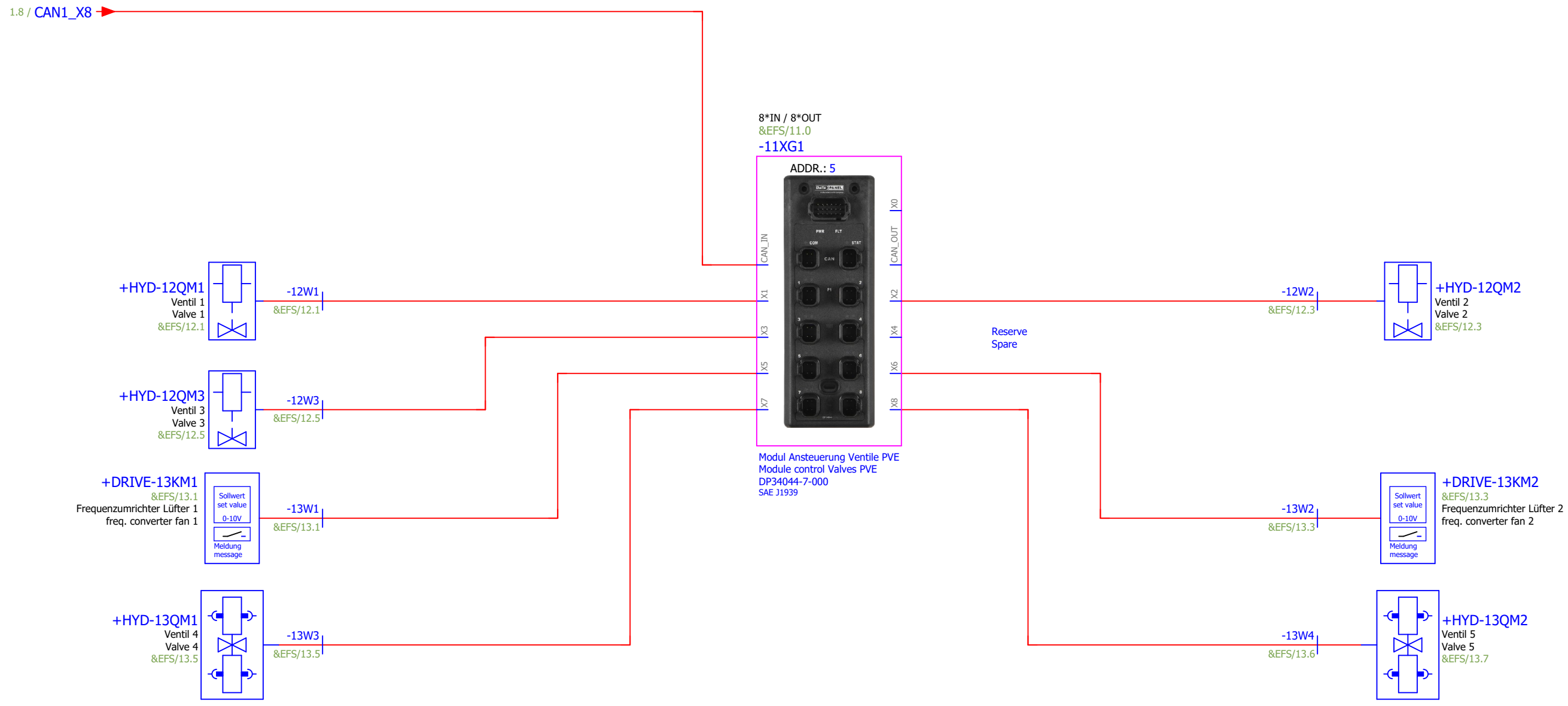

		Datum 04.02.2022		ANLAGE 1 - BEISPIEL		= UNIT1	
		Bearb. WR		Makro Dokumentation EPLAN V2.7 - V1.2		+ MA	
		Gepr		macro Documentation EPLAN V2.7 - V1.2			
Änderung	Datum	Name	Urspr	Ersatz von	Ersetzt durch	DAPA_MUSTERPROJEKT_EPL27_V1.2	
						Blatt 6	
						Blatt 30	



Gesamtübersicht Verteiler 5 - PVE
complete overview distributor 5 - PVE

Eigentum und Urheberrecht Fa. Data Panel - Schutzvermerk nach ISO 16016 beachten all rights and copyright Data Panel Corp. - observe protective note according to ISO 16016

SPS-Diagramm PLC diagram

F19_007_DPa1

Projektname
Project name DAPA_MUSTERPROJEKT_EPL27_V1.2

Adresse Address	Platzierung Placement	Symbolische Adresse Symbolic address	Funktionstext Function text	Betriebsmittelkennzeichen Aktor / Sensor Device tag Actuator / Sensor
--------------------	--------------------------	---	--------------------------------	--

=UNIT1+MA-2XG1

QX5.0	OUT 1A	4	X1	&EFS/5.2	QX5.0_X1:4	Zylinder 1 Cylinder 1	+DRIVE-5QM1
QX5.1	OUT 1B	2	X1	&EFS/5.1	QX5.1_X1:2	=	+DRIVE-5QM1
QX5.2	OUT 2A	4	X2	&EFS/5.4	QX5.2_X2:4	Zylinder 2 Cylinder 2	+DRIVE-5QM2
QX5.3	OUT_2B	2	X2	&EFS/5.3	QX5.3_X2:2	=	+DRIVE-5QM2
QX5.4	OUT_3A	4	X3	&EFS/5.6	QX5.4_X3:4	Zylinder 3 Cylinder 3	+DRIVE-5QM3
QX5.5	OUT_3B	2	X3	&EFS/5.5	QX5.5_X3:2	=	+DRIVE-5QM3
QX5.6	OUT 4A	4	X4	&EFS/5.8	QX5.6_X4:4	Zylinder 4 Cylinder 4	+DRIVE-5QM4
QX5.7	OUT 4B	2	X4	&EFS/5.7	QX5.7_X4:2	=	+DRIVE-5QM4
QX6.0	OUT 5A	4	X5	&EFS/2.1	QX6.0_X5:4	Reserve Spare	
QX6.1	OUT 5B	2	X5	&EFS/2.1	QX6.1_X5:2	=	
QX6.2	OUT 6A	4	X6	&EFS/2.2	QX6.2_X6:4	=	
QX6.3	OUT 6B	2	X6	&EFS/2.2	QX6.3_X6:2	=	
QX6.4	OUT 7A	4	X7	&EFS/2.1	QX6.4_X7:4	=	
QX6.5	OUT 7B	2	X7	&EFS/2.1	QX6.5_X7:2	=	
QX6.6	OUT 8A	4	X8	&EFS/2.2	QX6.6_X8:4	=	
QX6.7	OUT 8B	2	X8	&EFS/2.2	QX6.7_X8:2	=	

&EFA00/6

			Datum	04.02.2022	ANLAGE 1 - BEISPIEL		SPS-Diagramm : =UNIT1+MA-2XG1 - =UNIT1+MA-2XG1		= UNIT1	
			Bearb.	WR	Makro Dokumentation EPLAN V2.7 - V1.2		PLC diagram : =UNIT1+MA-2XG1 - =UNIT1+MA-2XG1		+ MA	
			Gepr		macro Documentation EPLAN V2.7 - V1.2				DAPA_MUSTERPROJEKT_EPL27_V1.2	
Änderung	Datum	Name	Urspr		Ersatz von	Ersetzt durch			Blatt	1
									Blatt	30

SPS-Diagramm PLC diagram

F19_007_DPa1

Projektname
Project name DAPA_MUSTERPROJEKT_EPL27_V1.2

Adresse Address	Platzierung Placement	Symbolische Adresse Symbolic address	Funktionstext Function text	Betriebsmittelkennzeichen Aktor / Sensor Device tag Actuator / Sensor
--------------------	--------------------------	---	--------------------------------	--

=UNIT1+MA-2XG3

Adresse Address	Platzierung Placement	Symbolische Adresse Symbolic address	Funktionstext Function text	Betriebsmittelkennzeichen Aktor / Sensor Device tag Actuator / Sensor
IX4.0	IN 1A 4	X1 &EFS/9.2 IX4.0_X1:4	Reserve Spare	
IW8	IN 1B 2	X1 &EFS/9.2 IW8_X1:2	Drehzahl Antrieb 1 Rated speed drive 1	+TRANS-9BG1
IX4.1	IN 2A 4	X2 &EFS/8.1 IX4.1_X2:4	Öl Druck 1 oil pressure 1	+DRIVE-8BP1
IX4.2	IN 2B 2	X2 &EFS/8.1 IX4.2_X2:2	Füllstand Öl Min. level oil min..	+DRIVE-8BL1
IX4.3	IN 3A 4	X3 &EFS/9.4 IX4.3_X2:4	Überwachung Position monitoring Position	+TRANS-8BS1
IX4.4	IN 3B 2	X3 &EFS/9.3 IX4.4_X3:2	=	+TRANS-8BS1
IX4.5	IN 4A 4	X4 &EFS/8.4 IX4.5_X4:4	Reserve Spare	
IW10	IN 4B 2	X4 &EFS/8.3 IW10_X4:2	Temperaturüberwachung temperature monitoring	+DRIVE-8BT1
IX4.6	IN 5A 4	X5 &EFS/8.6 IX4.6_X5:4	Reserve Spare	
IW12	IN 5B 2	X5 &EFS/8.5 IW12_X5:2	Füllstand Öl level oil	+DRIVE-8BP2
IX4.7	IN 6A 4	X6 &EFS/9.6 IX4.7_X6:4	Reserve Spare	
IX5.0	IN 6B 2	X6 &EFS/9.5 IX5.0_X6:2	Druck Bremse 1 pressure Brake 1	+TRANS-8BP1
IX5.1	IN 7A 4	X7 &EFS/9.8 IX5.1_X7:4	Reserve Spare	
IX5.2	IN 7B 2	X7 &EFS/9.7 IX5.2_X7:2	Druck Bremse 2 pressure Brake 2	+TRANS-8BP2
IX5.3	IN 8A 4	X8 &EFS/2.8 IX5.3_X8:4	Reserve Spare	
IW14	IN 8B 2	X8 &EFS/2.8 IW14_X8:2	=	

Eigentum und Urheberrecht Fa. Data Panel - Schutzvermerk nach ISO 16016 beachten all rights and copyright Data Panel Corp. - observe protective note according to ISO 16016

Datum	04.02.2022	ANLAGE 1 - BEISPIEL		 SPS-Diagramm : =UNIT1+MA-2XG3 - =UNIT1+MA-2XG3 PLC diagram : =UNIT1+MA-2XG3 - =UNIT1+MA-2XG3	= UNIT1	
Bearb.	WR	Makro Dokumentation EPLAN V2.7 - V1.2			+ MA	
Gepr		macro Documentation EPLAN V2.7 - V1.2			DAPA_MUSTERPROJEKT_EPL27_V1.2	
Änderung	Datum	Name	Urspr	Ersatz von	Ersetzt durch	Blatt 3
						Blatt 30

SPS-Diagramm PLC diagram

F19_007_DPa1

Projektname
Project name DAPA_MUSTERPROJEKT_EPL27_V1.2

Adresse Address	Platzierung Placement	Symbolische Adresse Symbolic address	Funktionstext Function text	Betriebsmittelkennzeichen Aktor / Sensor Device tag Actuator / Sensor
--------------------	--------------------------	---	--------------------------------	--

=UNIT1+MA-11XG1

QW100	OUT 1A	1	X1	&EFS/12.1	QW100_X1:1	Ventil 1 Valve 1	+HYD-12QM1
IX100.0	IN 1B	2	X1	&EFS/12.1	IX100.0_X1:2	=	+HYD-12QM1
QW102	OUT 2A	1	X2	&EFS/12.3	QW102_X2:1	Ventil 2 Valve 2	+HYD-12QM2
IX100.1	IN 2B	2	X2	&EFS/12.3	IX100.1_X2:2	=	+HYD-12QM2
QW104	OUT 3A	1	X3	&EFS/12.5	QW104_X3:1	Ventil 3 Valve 3	+HYD-12QM3
IX100.2	IN 3B	2	X3	&EFS/12.5	IX100.2_X3:2	=	+HYD-12QM3
QW106	OUT 4A	1	X4	&EFS/12.7	QW106_X4:1	Reserve Spare	
IX100.3	IN 4B	2	X4	&EFS/12.7	IX100.3_X4:2	=	
QW108	OUT 5A	1	X5	&EFS/13.1	QW108_X5:1	Frequenzumrichter Lüfter 1 freq. converter fan 1	+DRIVE-13KM1
IX100.4	IN 5B	2	X5	&EFS/13.1	IX100.4_X5:2	=	+DRIVE-13KM1
QW110	OUT 6A	1	X6	&EFS/13.3	QW110_X6:1	Frequenzumrichter Lüfter 2 freq. converter fan 2	+DRIVE-13KM2
IX100.5	IN 6B	2	X6	&EFS/13.3	IX100.5_X6:2	=	+DRIVE-13KM2
QX100.0	OUT 7A	1	X7	&EFS/13.5	QX100.0_X7:1	Ventil 4 Valve 4	+HYD-13QM1
QX100.1	OUT 7B	4	X7	&EFS/13.6	QX100.1_X7:4	=	+HYD-13QM1
QX100.2	OUT 8A	1	X8	&EFS/13.7	QX100.2_X8:1	Ventil 5 Valve 5	+HYD-13QM2
QX100.3	OUT 8B	4	X8	&EFS/13.7	QX100.3_X8:4	=	+HYD-13QM2

Eigentum und Urheberrecht Fa. Data Panel - Schutzvermerk nach ISO 16016 beachten all rights and copyright Data Panel Corp. - observe protective note according to ISO 16016

&EFS/1

4			Datum	04.02.2022	ANLAGE 1 - BEISPIEL			SPS-Diagramm : =UNIT1+MA-11XG1 - =UNIT1+MA-11XG1 PLC diagram : =UNIT1+MA-11XG1 - =UNIT1+MA-11XG1	= UNIT1			
			Bearb.	WR	Makro Dokumentation EPLAN V2.7 - V1.2				+ MA		Blatt	5
			Gepr		macro Documentation EPLAN V2.7 - V1.2				DAPA_MUSTERPROJEKT_EPL27_V1.2		Blatt	30
Änderung	Datum	Name	Urspr		Ersatz von	Ersetzt durch						

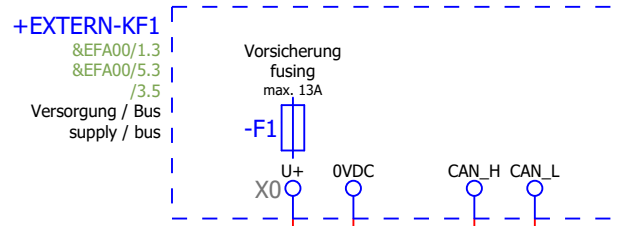
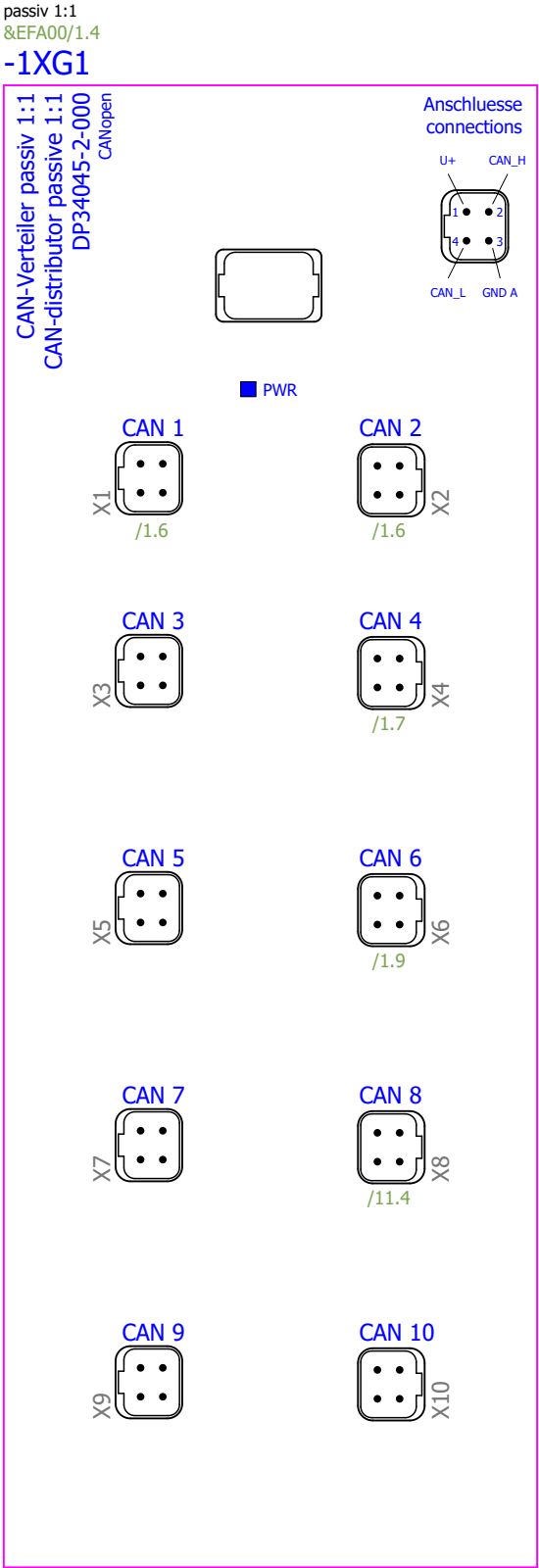
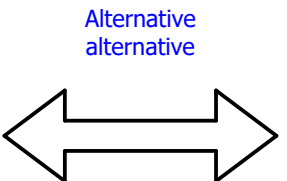
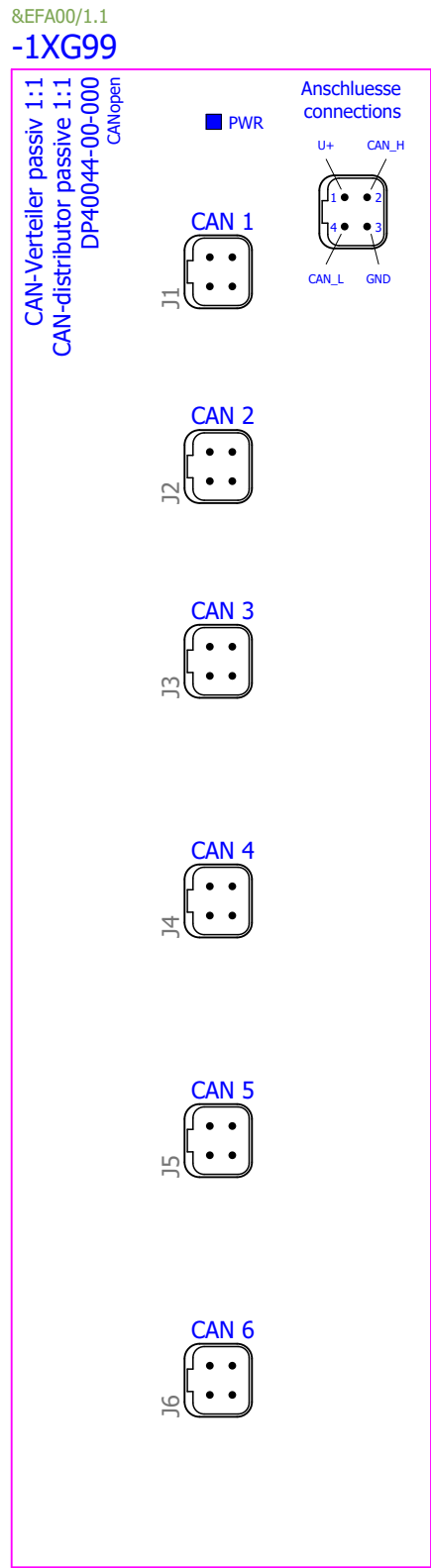

Kunde
Customer

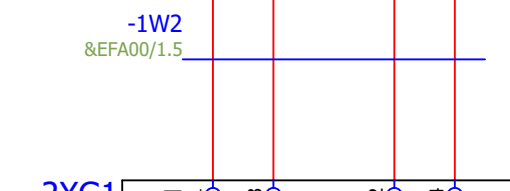
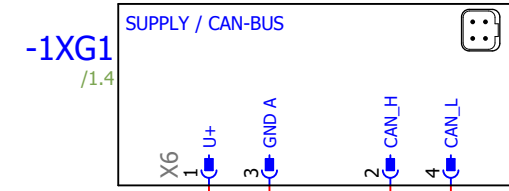
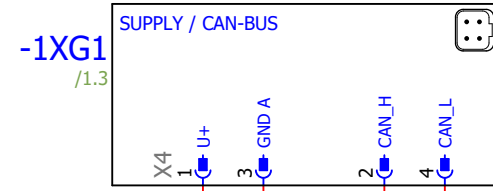
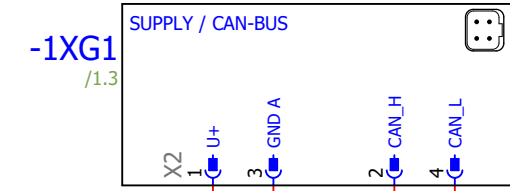
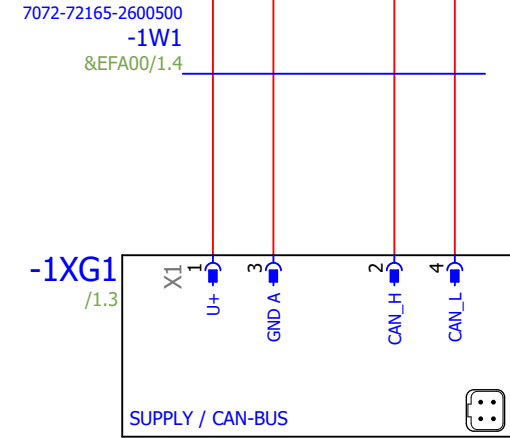

Spannungsversorgung / Bus
Power supply / bus

ANLAGE 1 - BEISPIEL		Makro Dokumentation EPLAN V2.7 - V1.2		macro Documentation EPLAN V2.7 - V1.2		= UNIT1		+ MA	
Datum	04.02.2022	Bearb.	WR						
Gepr.									
Änderung	Datum	Name	Urspr	Ersatz von	Ersetzt durch	DAPA_MUSTERPROJEKT_EPL27_V1.2		Blatt	1
								Blatt	30

&EFA00/2.4

-2XG1

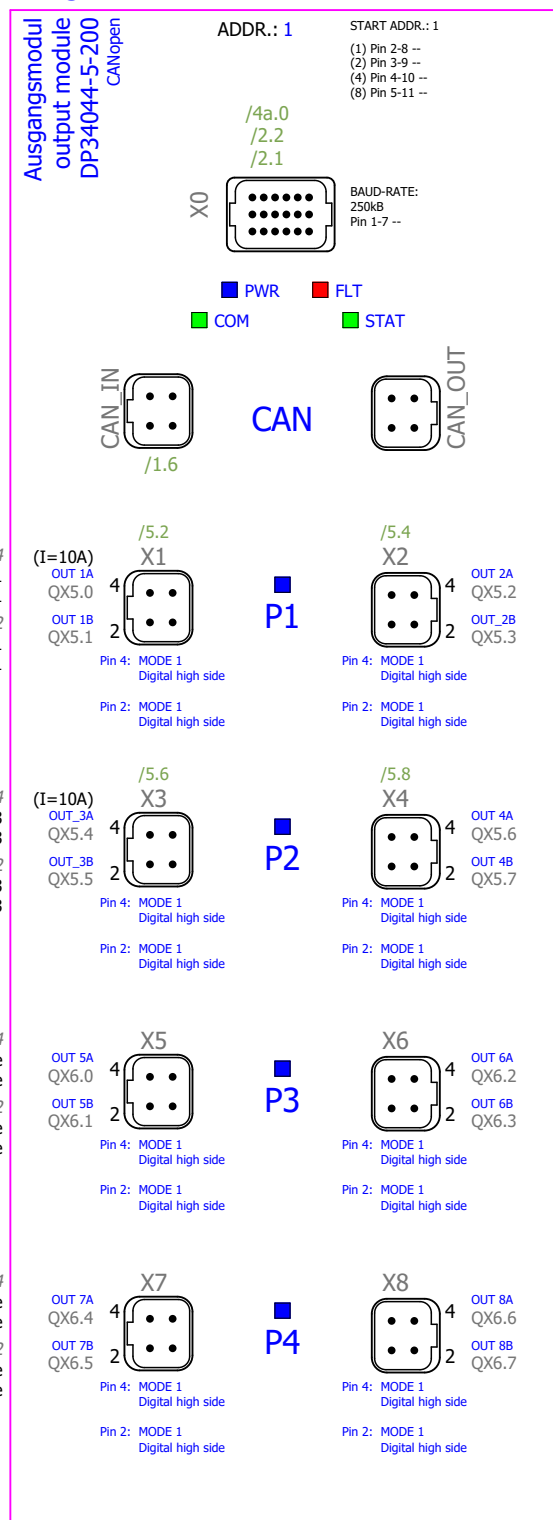

&EFA00/3.4

-2XG2

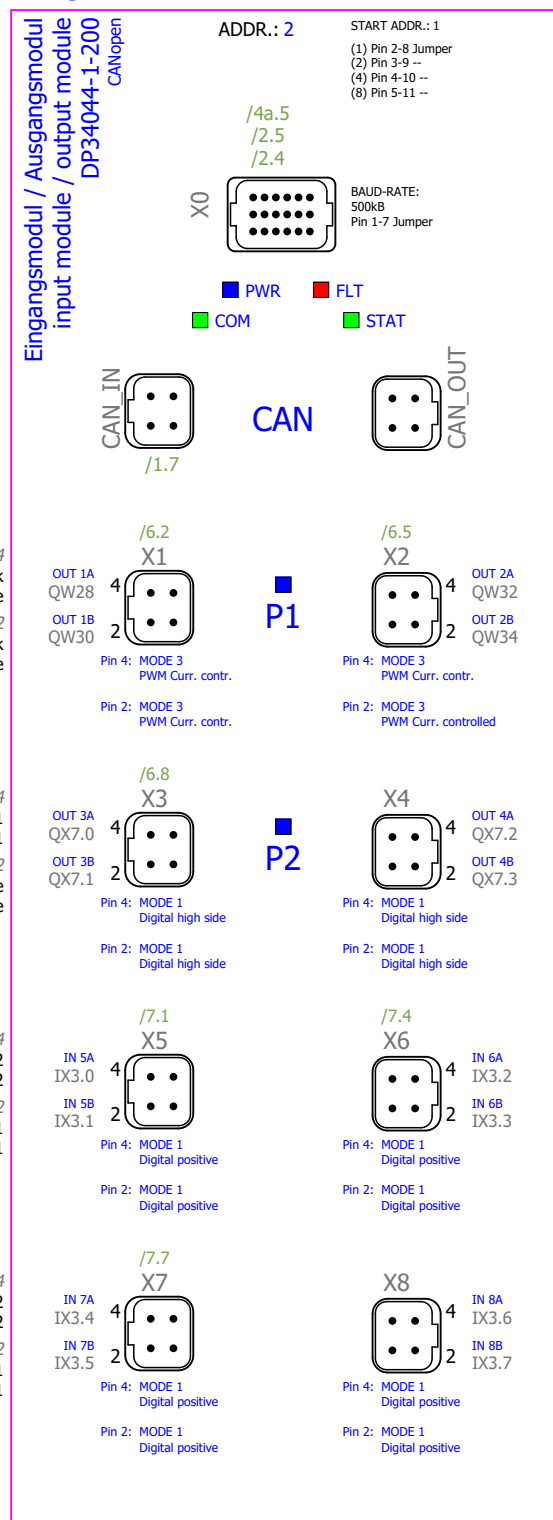

16*IN
&EFA00/4.4

-2XG3

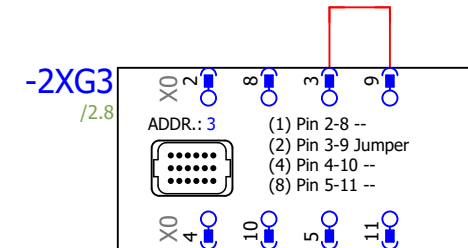
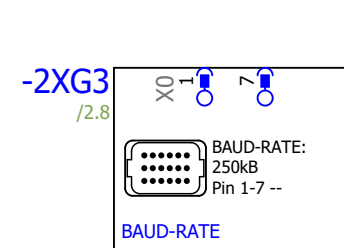
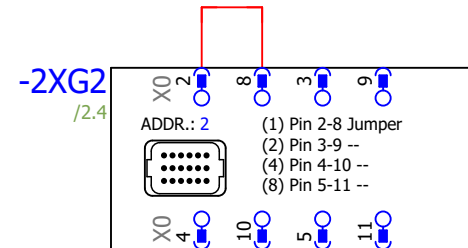
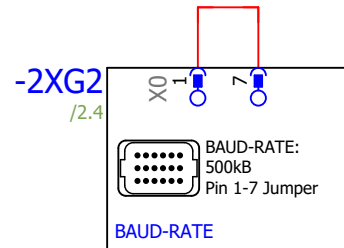
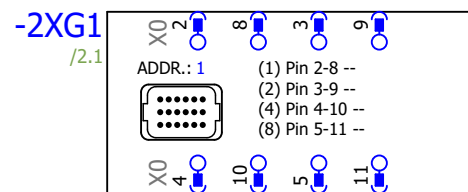
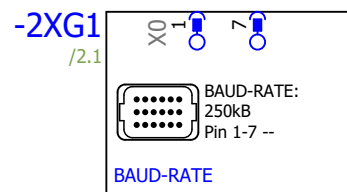
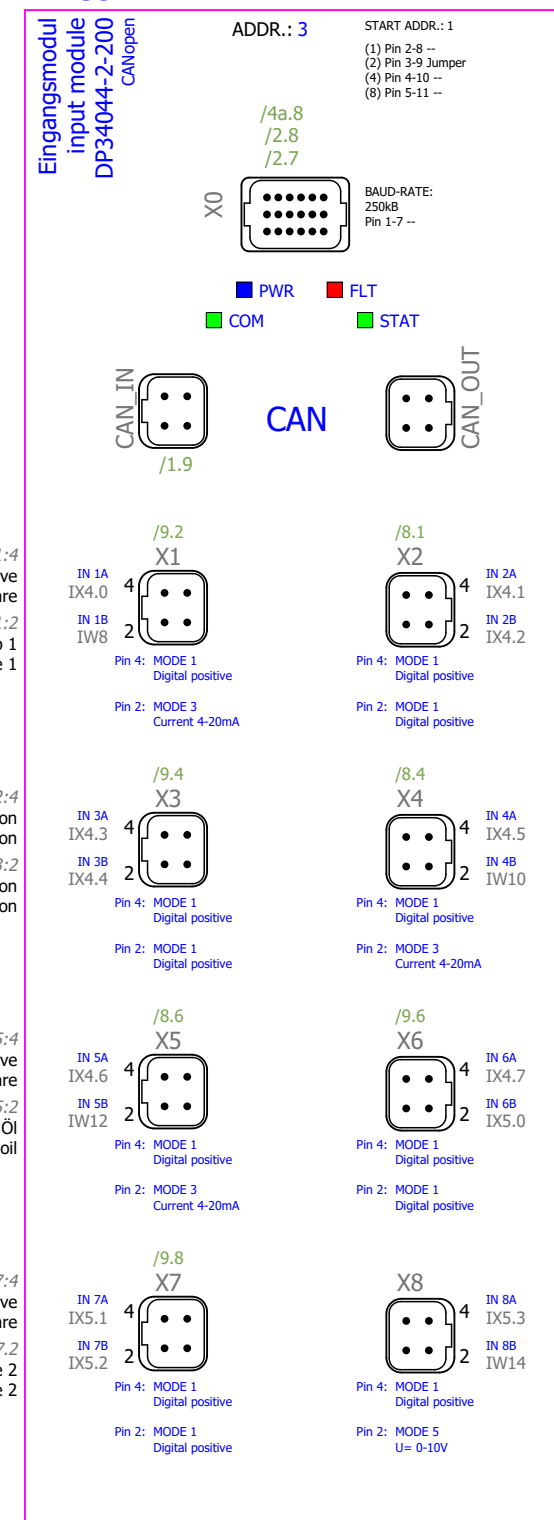

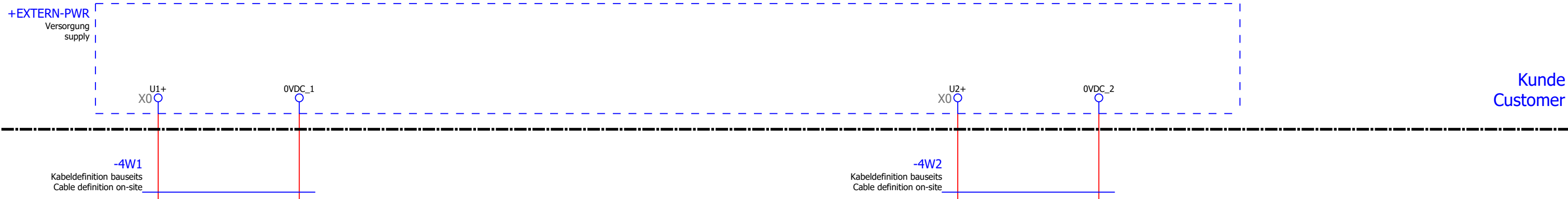

Kunde
Customer

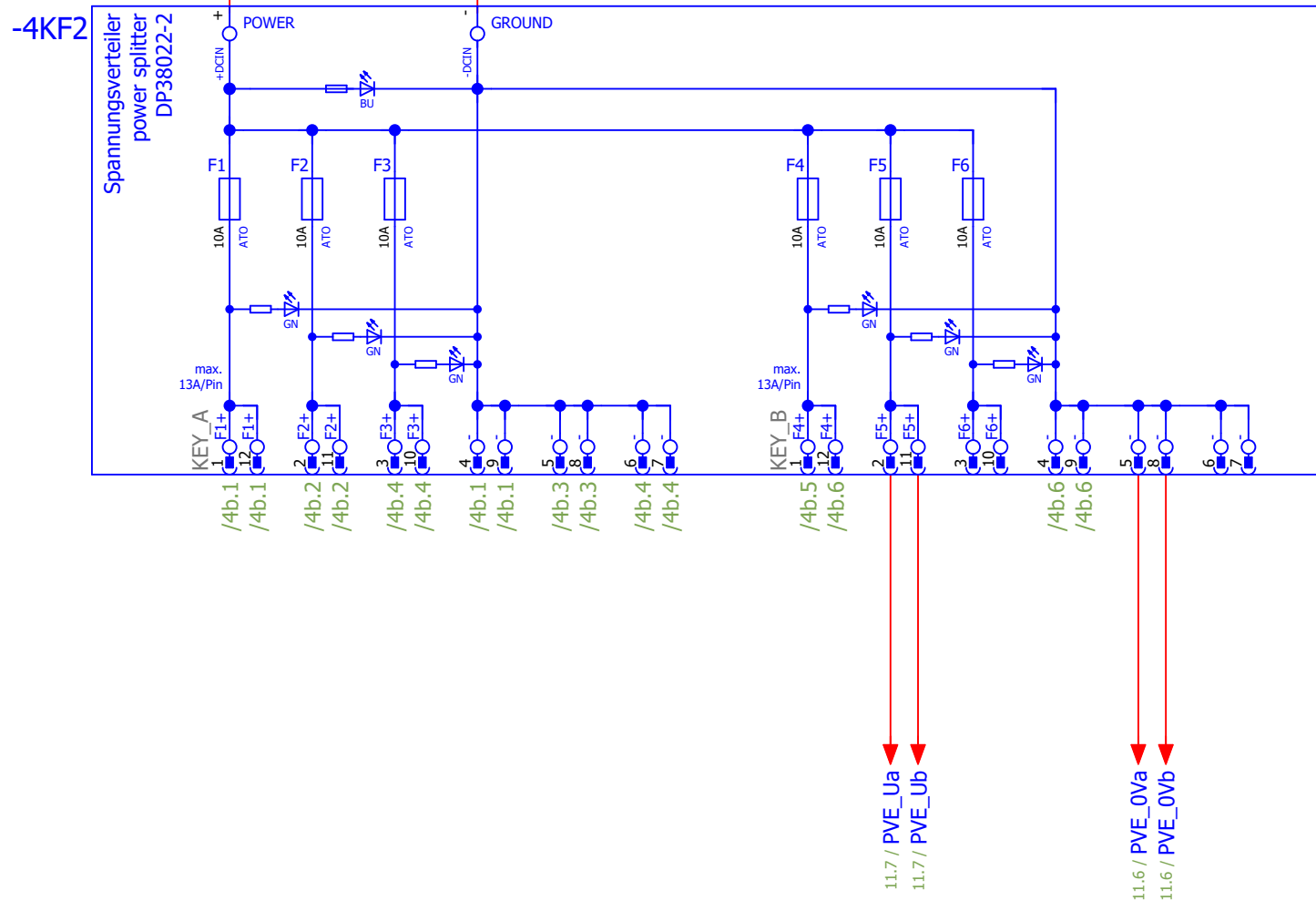
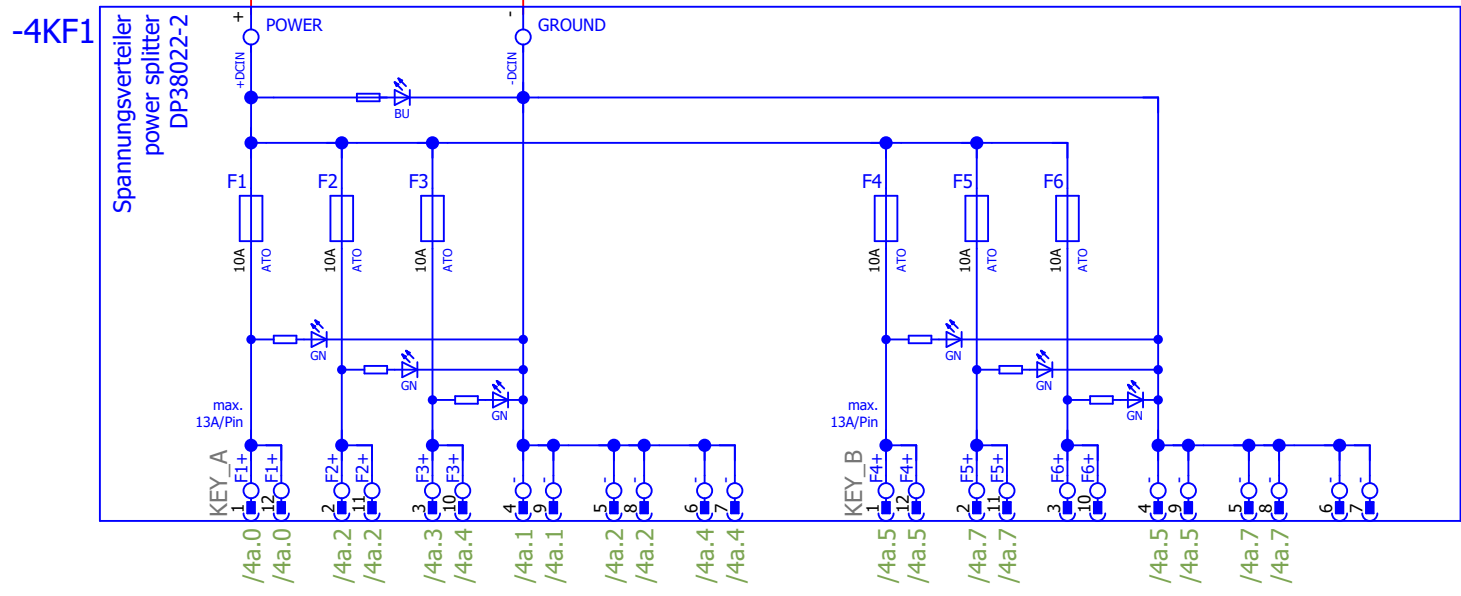

Spannungsverteiler 1
power splitter 1

Spannungsverteiler 1
power splitter 1

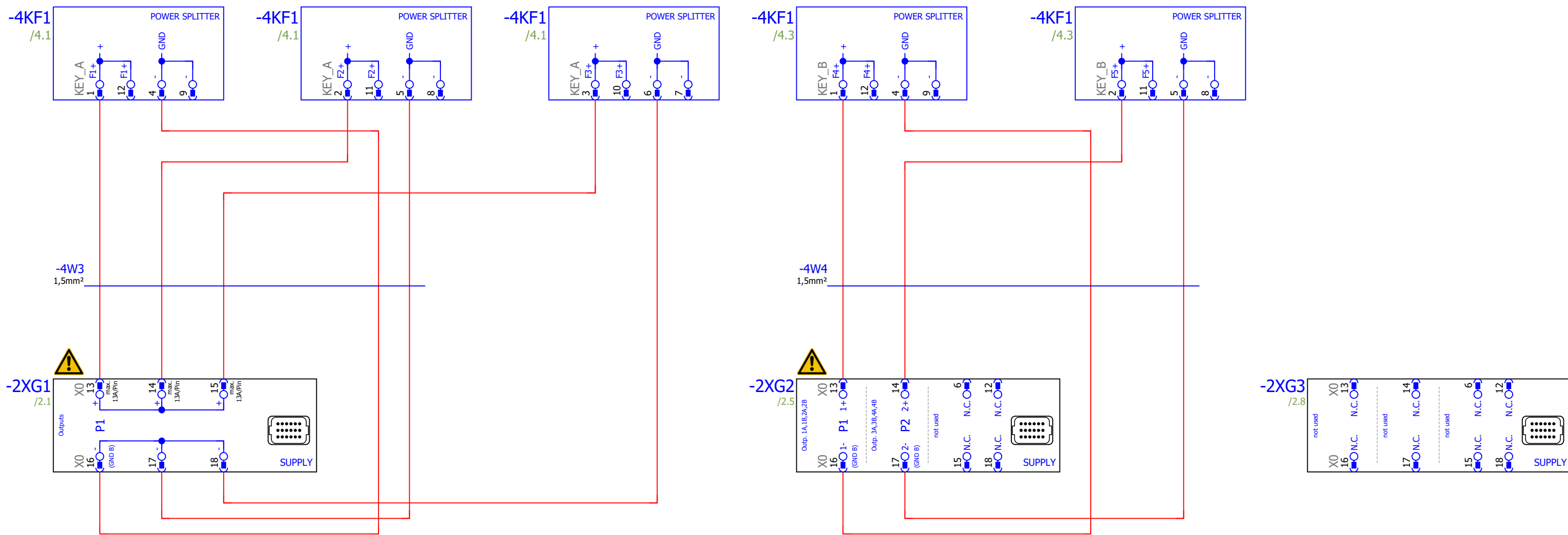

Spannungsversorgung / Konfiguration
Power supply / configuration

**Achtung!
caution!**
Summenstrom max. 13A / Kanal
total current max. 13A / channel

/2.1
-2XG1

ADDR.: 1

Zylinder 1 Cylinder 1	Zylinder 1 Cylinder 1
-QX5.1_X1:2	-QX5.0_X1:4
QX5.1	QX5.0
X1 1 GND B	3 GND B
2 OUT 1B	4 OUT 1A (I=10A)

7072-77801-6370250
-5W1
&EFA00/2.2

**+DRIVE
-5QM1**
&EFA00/2.1

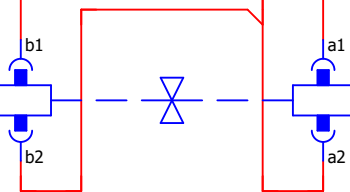

Zylinder 1
Cylinder 1

/2.2
-2XG1

ADDR.: 1

Zylinder 2 Cylinder 2	Zylinder 2 Cylinder 2
-QX5.3_X2:2	-QX5.2_X2:4
QX5.3	QX5.2
X2 1 GND B	3 GND B
2 OUT 2B	4 OUT 2A

7072-77801-6370250
-5W2
&EFA00/2.7

**+DRIVE
-5QM2**
&EFA00/2.7

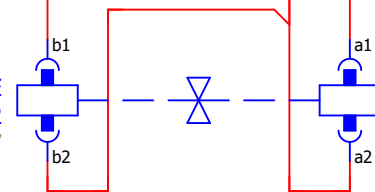

Zylinder 2
Cylinder 2

/2.1
-2XG1

ADDR.: 1

Zylinder 3 Cylinder 3	Zylinder 3 Cylinder 3
-QX5.5_X3:2	-QX5.4_X3:4
QX5.5	QX5.4
X3 1 GND B	3 GND B
2 OUT 3B	4 OUT 3A (I=10A)

7072-77801-6370250
-5W3
&EFA00/2.2

**+DRIVE
-5QM3**
&EFA00/2.1

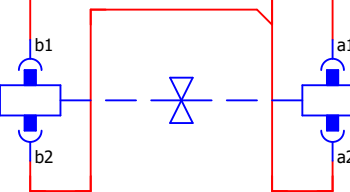

Zylinder 3
Cylinder 3

/2.2
-2XG1

ADDR.: 1

Zylinder 4 Cylinder 4	Zylinder 4 Cylinder 4
-QX5.7_X4:2	-QX5.6_X4:4
QX5.7	QX5.6
X4 1 GND B	3 GND B
2 OUT 4B	4 OUT 4A

7072-77801-6370250
-5W4
&EFA00/2.7

**+DRIVE
-5QM4**
&EFA00/2.7

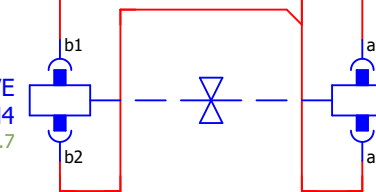

Zylinder 4
Cylinder 4

			Datum	04.02.2022	ANLAGE 1 - BEISPIEL		= UNIT1	
			Bearb.	WR	Makro Dokumentation EPLAN V2.7 - V1.2		+ MA	
			Gepr		macro Documentation EPLAN V2.7 - V1.2		Blatt 5	
Änderung	Datum	Name	Urspr		Ersatz von	Ersetzt durch	DAPA_MUSTERPROJEKT_EPL27_V1.2	
							Blatt 30	

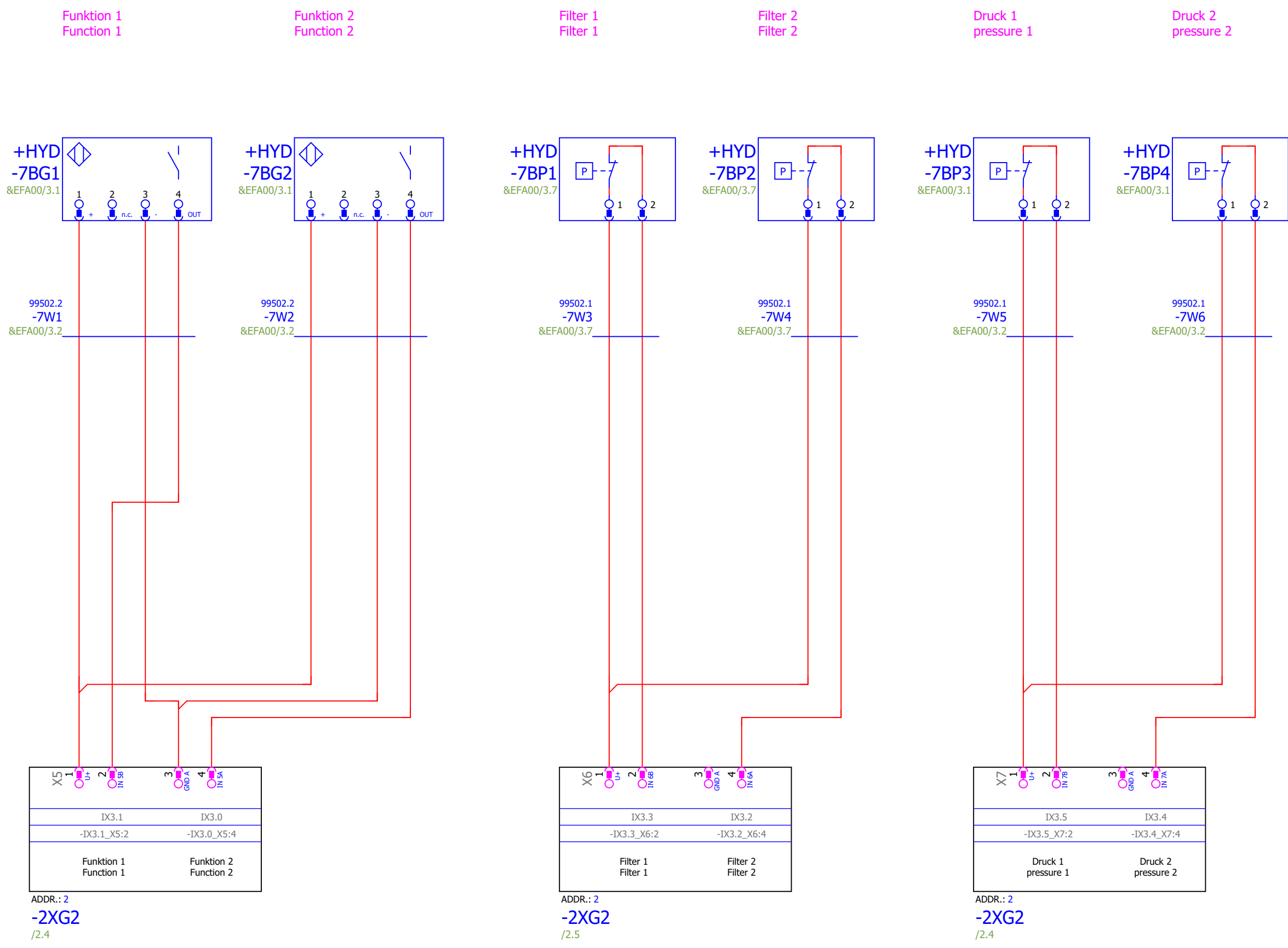

Füllstand Öl Min.
level oil min..

Öl Druck 1
oil pressure 1

Temperaturüberwachung
temperature monitoring

Reserve
Spare

Füllstand Öl
level oil

Reserve
Spare

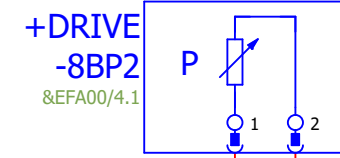
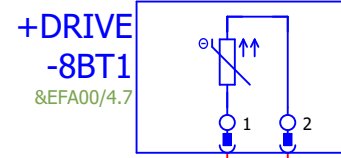
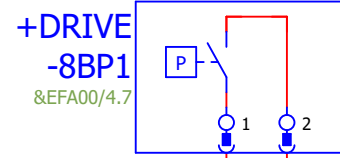
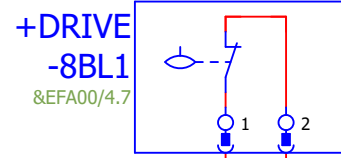

99502.1
-8W1
&EFA00/4.7

99502.1
-8W2
&EFA00/4.7

99502.3
-8W3
&EFA00/4.7

99502.3
-8W4
&EFA00/4.2

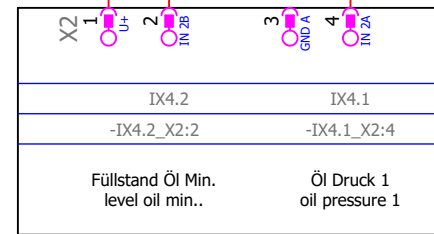

ADDR.: 3
-2XG3
/2.8

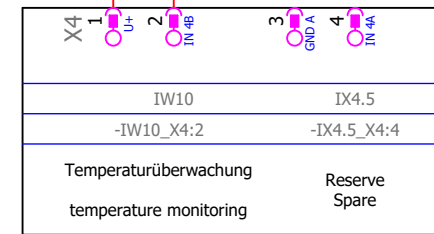

ADDR.: 3
-2XG3
/2.8

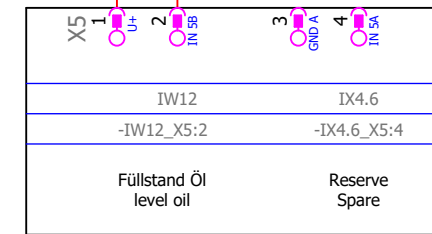

ADDR.: 3
-2XG3
/2.7

Drehzahl Antrieb 1
Rated speed drive 1

Reserve
Spare

Überwachung Position
monitoring Position

Druck Bremse 1
pressure Brake 1

Reserve
Spare

Druck Bremse 2
pressure Brake 2

Reserve
Spare

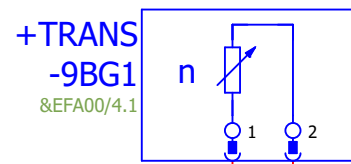

99502.3
-9W1
&EFA00/4.2

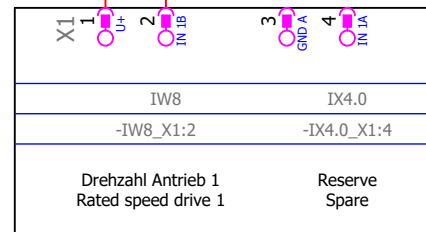

ADDR.: 3
-2XG3
/2.7

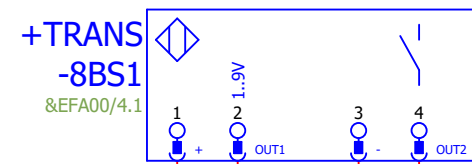

7072-77301-5691000
-9W2
&EFA00/4.2

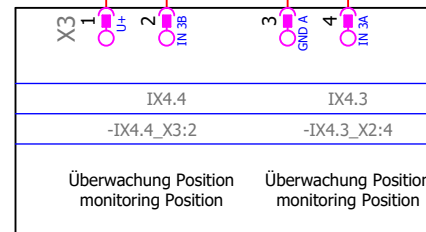

ADDR.: 3
-2XG3
/2.7

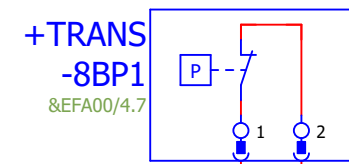

99502.3
-9W3
&EFA00/4.7

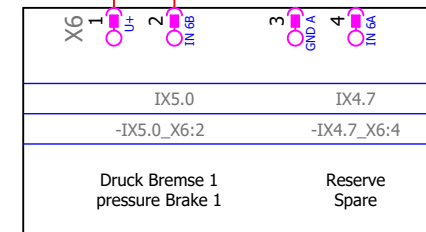

ADDR.: 3
-2XG3
/2.8

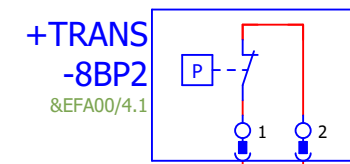

99502.3
-9W4
&EFA00/4.2

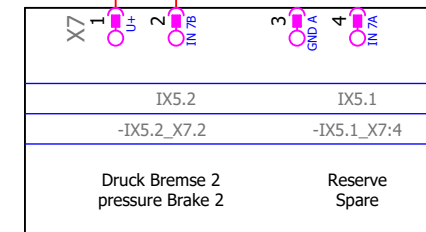

ADDR.: 3
-2XG3
/2.7

			Datum	04.02.2022	ANLAGE 1 - BEISPIEL						= UNIT1	
			Bearb.	WR	Makro Dokumentation EPLAN V2.7 - V1.2		DATA PANEL		Stromlaufplan IN Verteiler 3		+ MA	
			Gepr		macro Documentation EPLAN V2.7 - V1.2		POWERED BY MURRELEKTRONIK		wiring diagram IN distributor 3		Blatt 9	
Änderung	Datum	Name	Urspr		Ersatz von	Ersetzt durch	DAPA_MUSTERPROJEKT_EPL27_V1.2				Blatt 30	

/3.1
-3XG1

ADDR.: 4

Zylinder 5 Cylinder 5	Zylinder 5 Cylinder 5
-QW38_X7:2	-QW36_X7:4
QW38	QW36
X7 1 GND B 2 OUT 7B	3 GND B 4 OUT 7A

7072-77801-6370250
-10W1
&EFA00/5.2

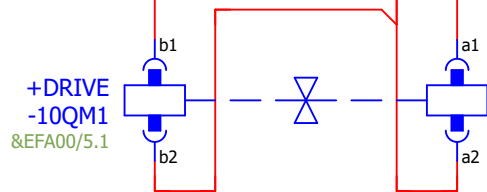

Zylinder 5
Cylinder 5

/3.2
-3XG1

ADDR.: 4

Pumpe 3 Druck Pump 3 pressure	Pumpe 3 Druck Pump 3 pressure
-QW42_X8:2	-QW40_X8:4
QW42	QW40
X8 1 GND B 2 OUT 8B	3 GND B 4 OUT 8A

99502.4
-10W2
&EFA00/5.7

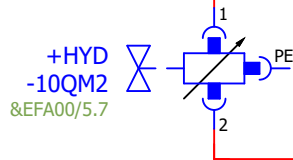

Pumpe 3 Druck
Pump 3 pressure

99502.4
-10W3
&EFA00/5.7

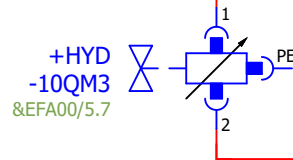

Pumpe 3 Druck
Pump 3 pressure

/3.1
-3XG1

ADDR.: 4

Reserve Spare	Hydraulik Funktion 2 Hydraulics Function 2
-QX8.1_X1:2	-QX8.0_X1:4
QX8.1	QX8.0
X1 1 GND B 2 OUT 1B	3 GND B 4 OUT 1A (I=10A)

7072-77731-7540150
-10W4
&EFA00/5.2

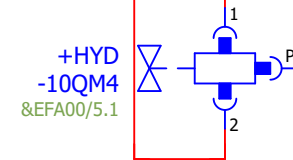

Reserve
Spare

Hydraulik Funktion 2
Hydraulics Function 2

		Datum	07.02.2022	ANLAGE 1 - BEISPIEL			Stromlaufplan OUT PWM(i) Verteiler 4} !! XXXXXXXXXXXX !!	= UNIT1	
		Bearb.	WR	Makro Dokumentation EPLAN V2.7 - V1.2				+ MA	
		Gepr		macro Documentation EPLAN V2.7 - V1.2				Blatt 10	
Änderung	Datum	Name	Urspr	Ersatz von	Ersetzt durch	DAPA_MUSTERPROJEKT_EPL27_V1.2		Blatt 30	

8*IN / 8*OUT
&EFA00/6.4
-11XG1

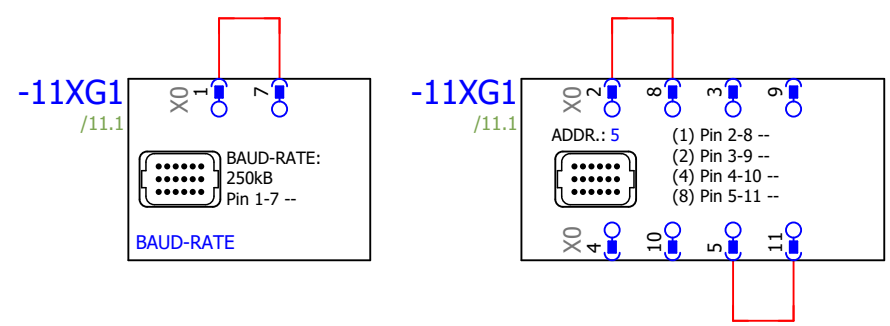
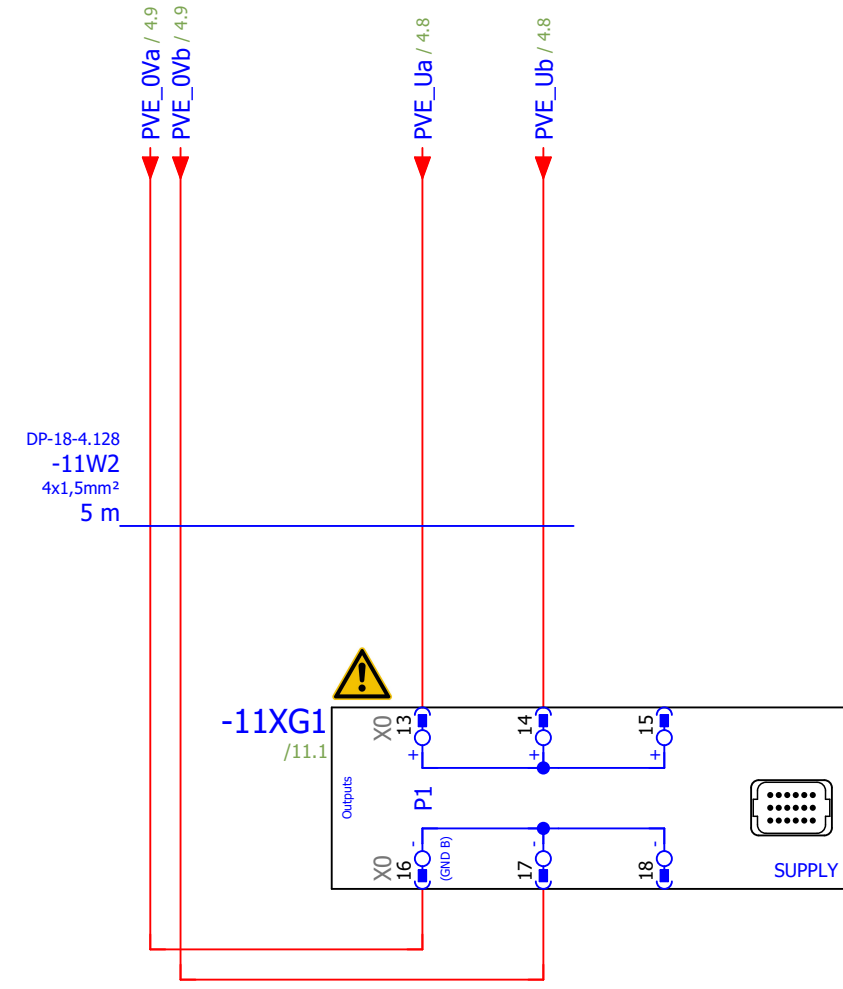
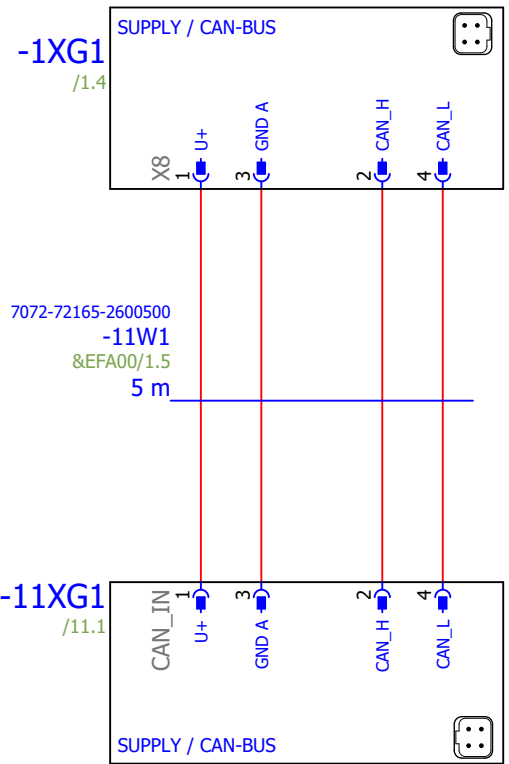
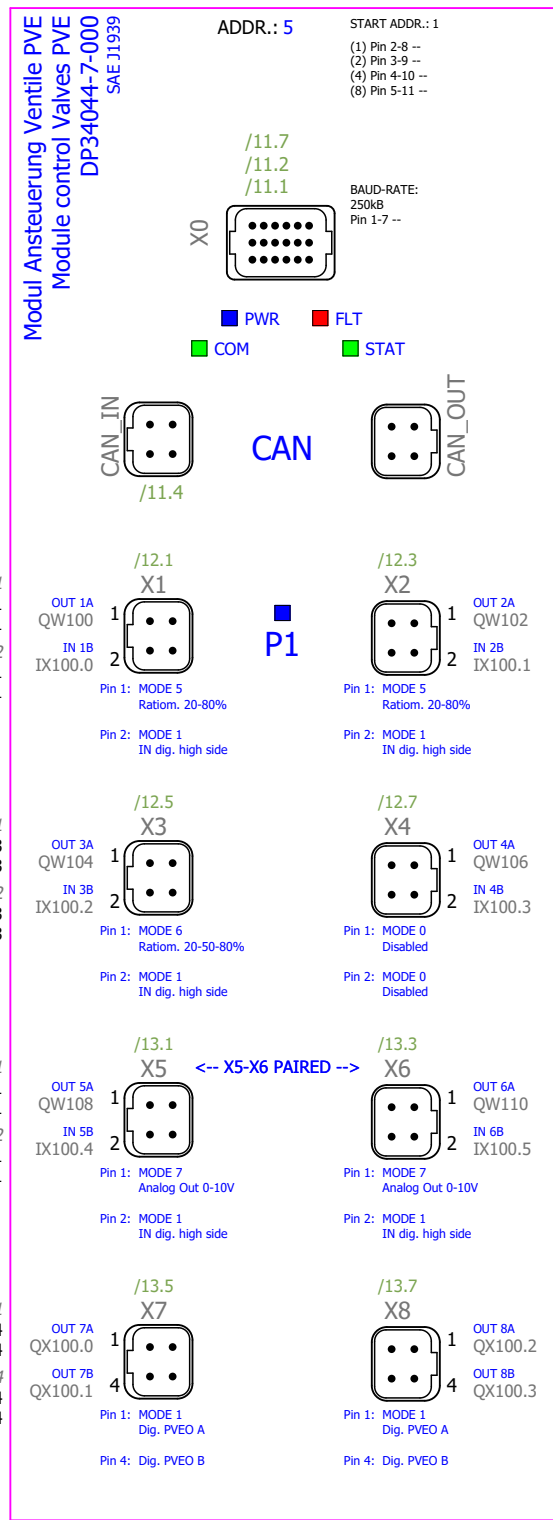

Spannungsversorgung / Bus
Power supply / bus

Spannungsversorgung / Konfiguration
Power supply / configuration

Achtung!
caution!
Summenstrom max. 13A / Kanal
total current max. 13A / channel

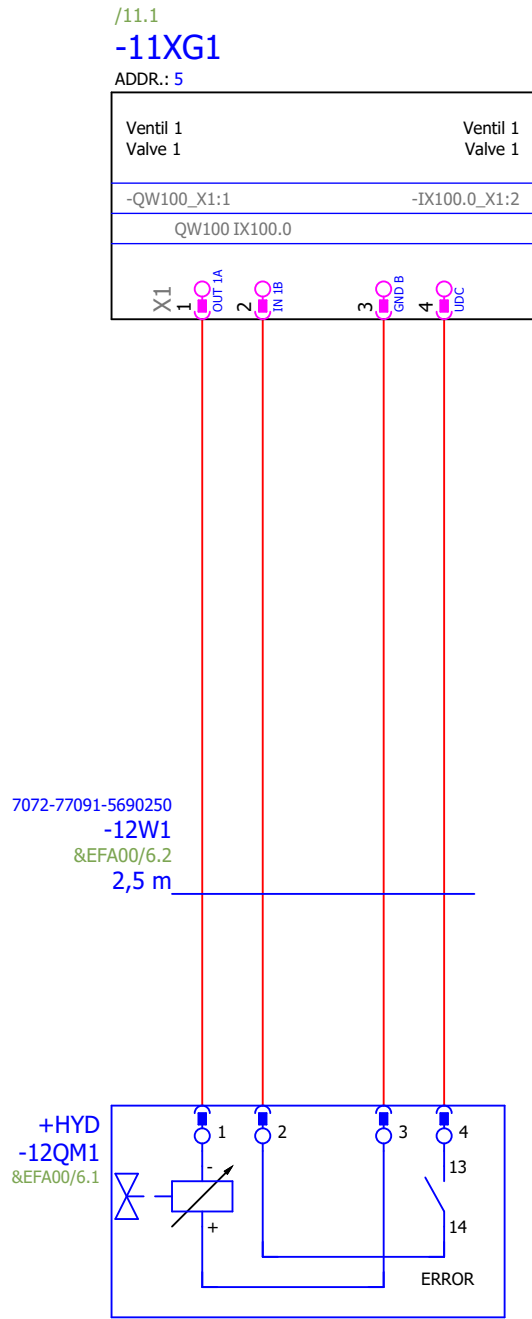

Ventil 1
Valve 1

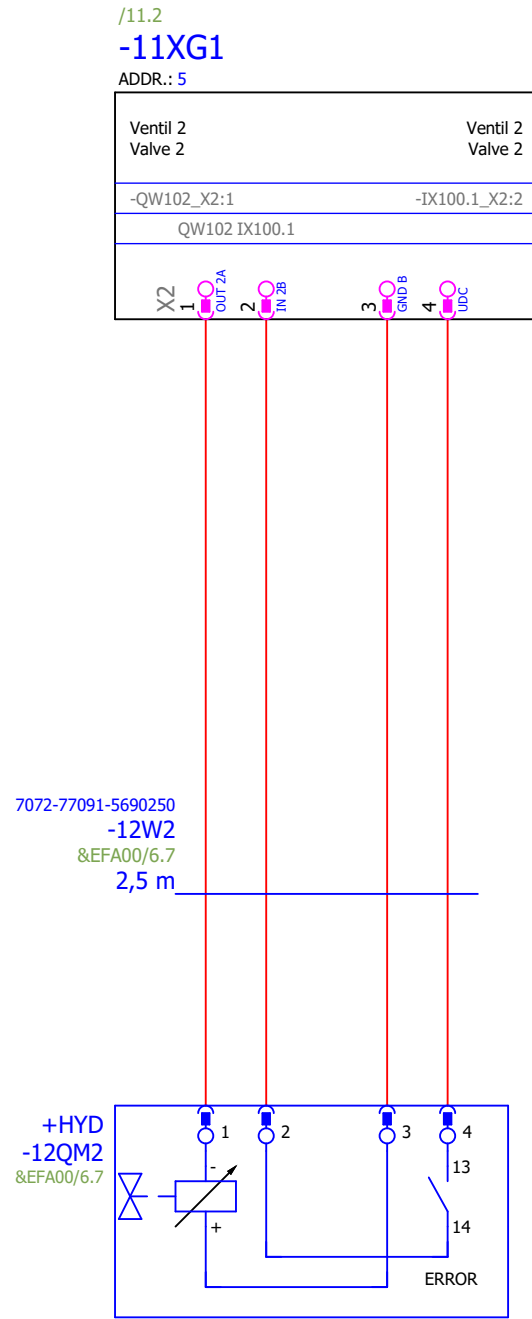

Ventil 2
Valve 2

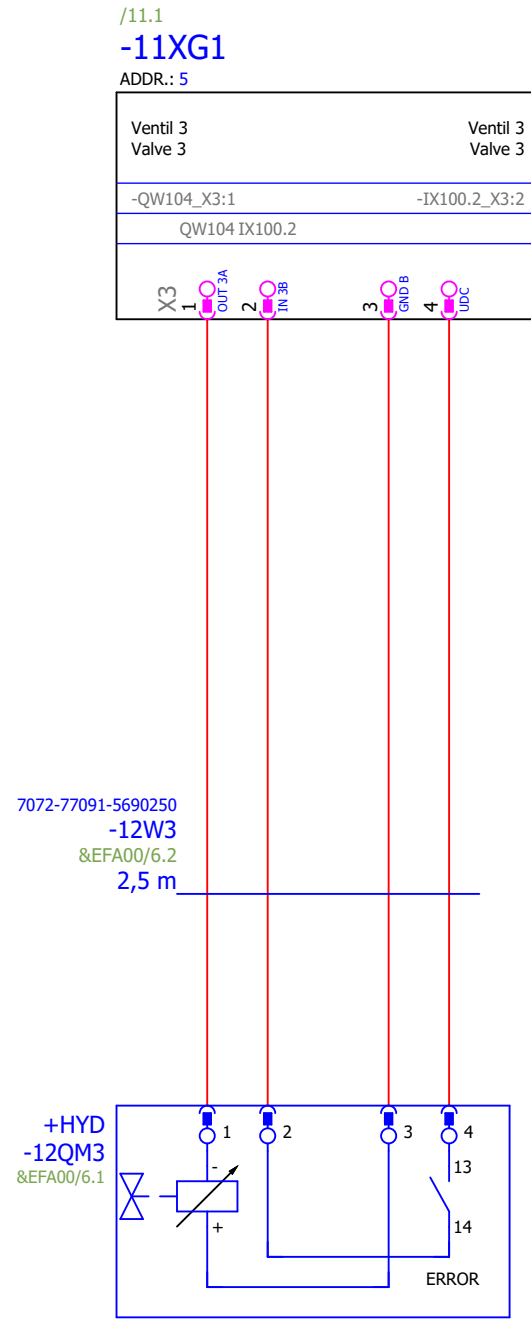

Ventil 3
Valve 3

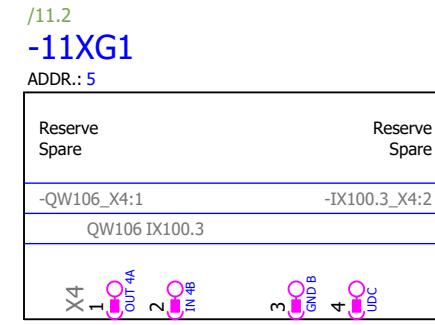

Reserve
Spare

			Datum	04.02.2022	ANLAGE 1 - BEISPIEL		= UNIT1	
			Bearb.	WR	Makro Dokumentation EPLAN V2.7 - V1.2		+ MA	
			Gepr		macro Documentation EPLAN V2.7 - V1.2		Blatt 12	
Änderung	Datum	Name	Urspr		Ersatz von	Ersetzt durch	DAPA_MUSTERPROJEKT_EPL27_V1.2	
							Blatt 30	

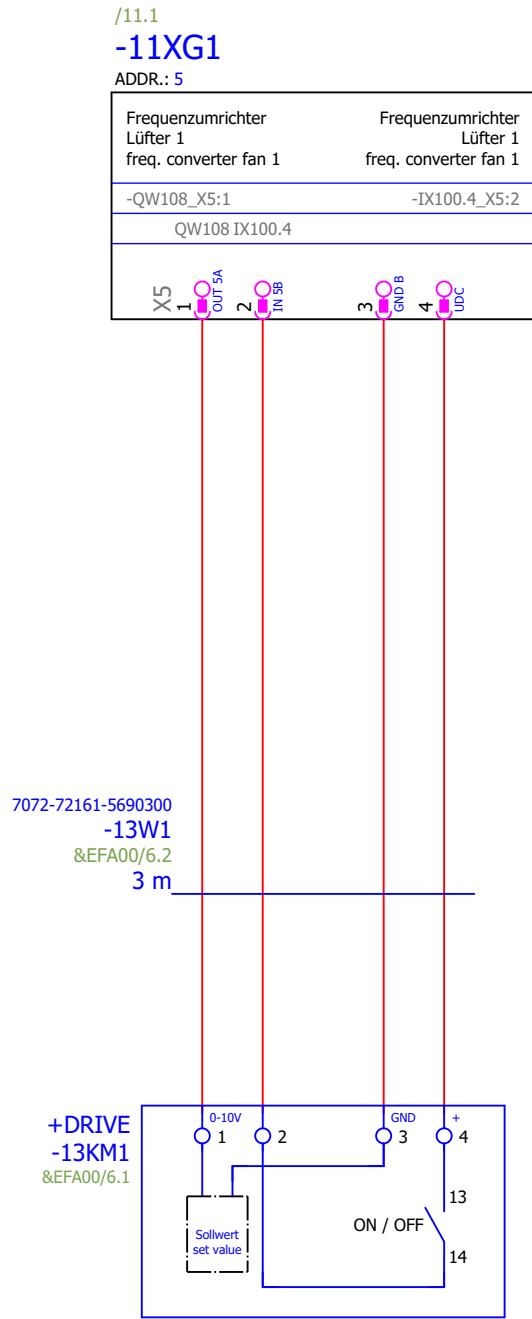

Frequenzumrichter Lüfter 1
freq. converter fan 1

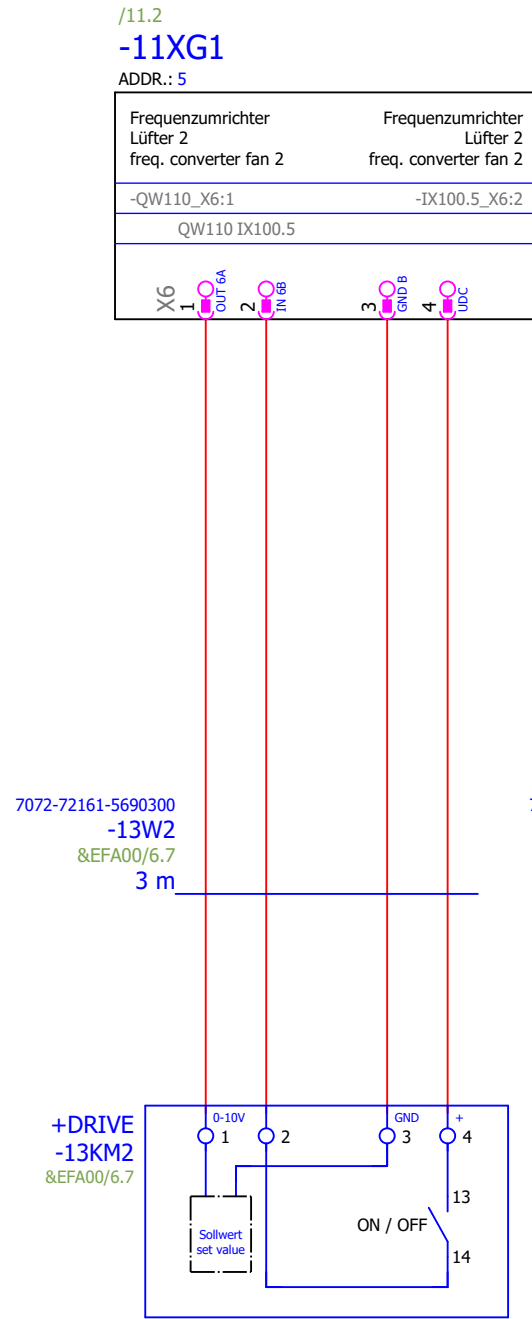

Frequenzumrichter Lüfter 2
freq. converter fan 2

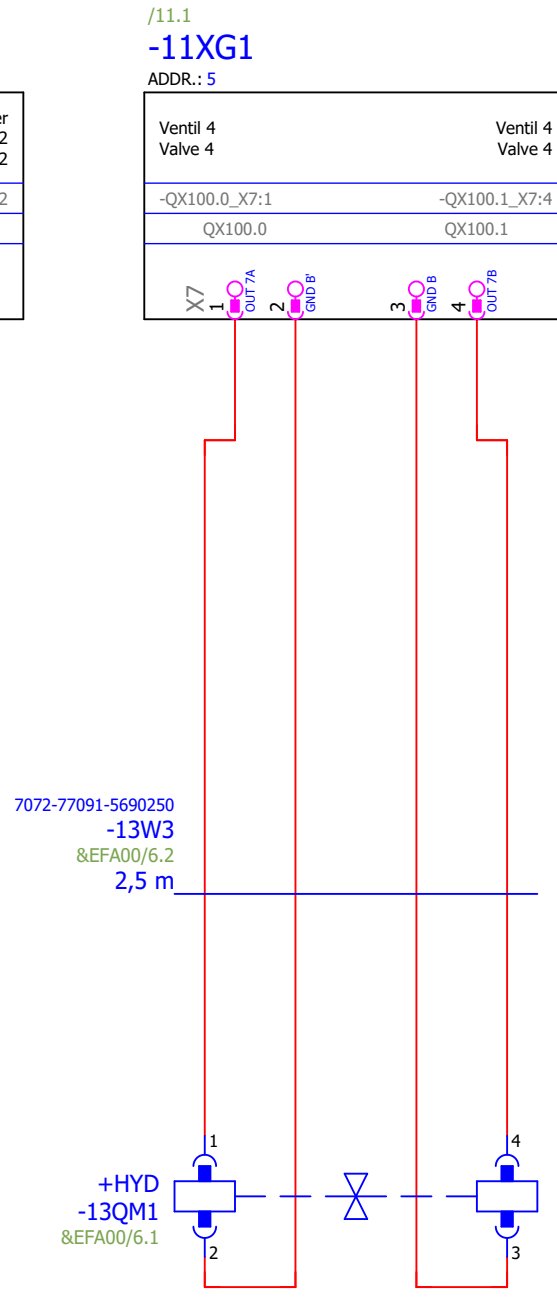

Ventil 4
Valve 4

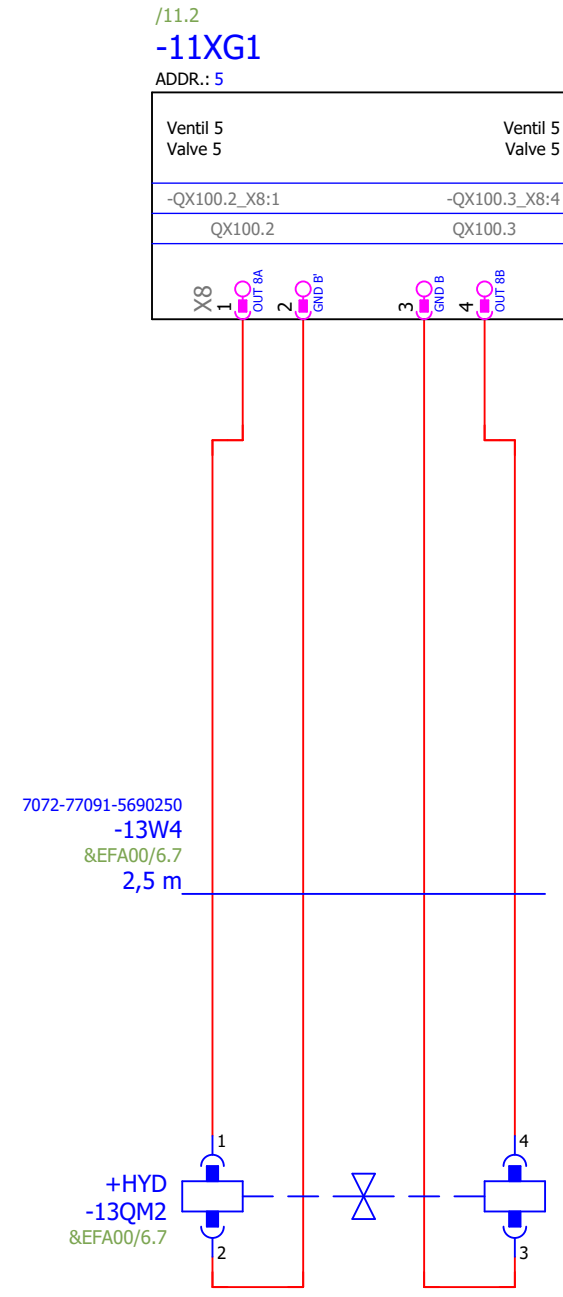

Ventil 5
Valve 5

			Datum	04.02.2022	ANLAGE 1 - BEISPIEL		= UNIT1	
			Bearb.	WR	Makro Dokumentation EPLAN V2.7 - V1.2		+ MA	
			Gepr		macro Documentation EPLAN V2.7 - V1.2		Blatt 13	
Änderung	Datum	Name	Urspr		Ersatz von	Ersetzt durch	DAPA_MUSTERPROJEKT_EPL27_V1.2	
							Blatt 30	

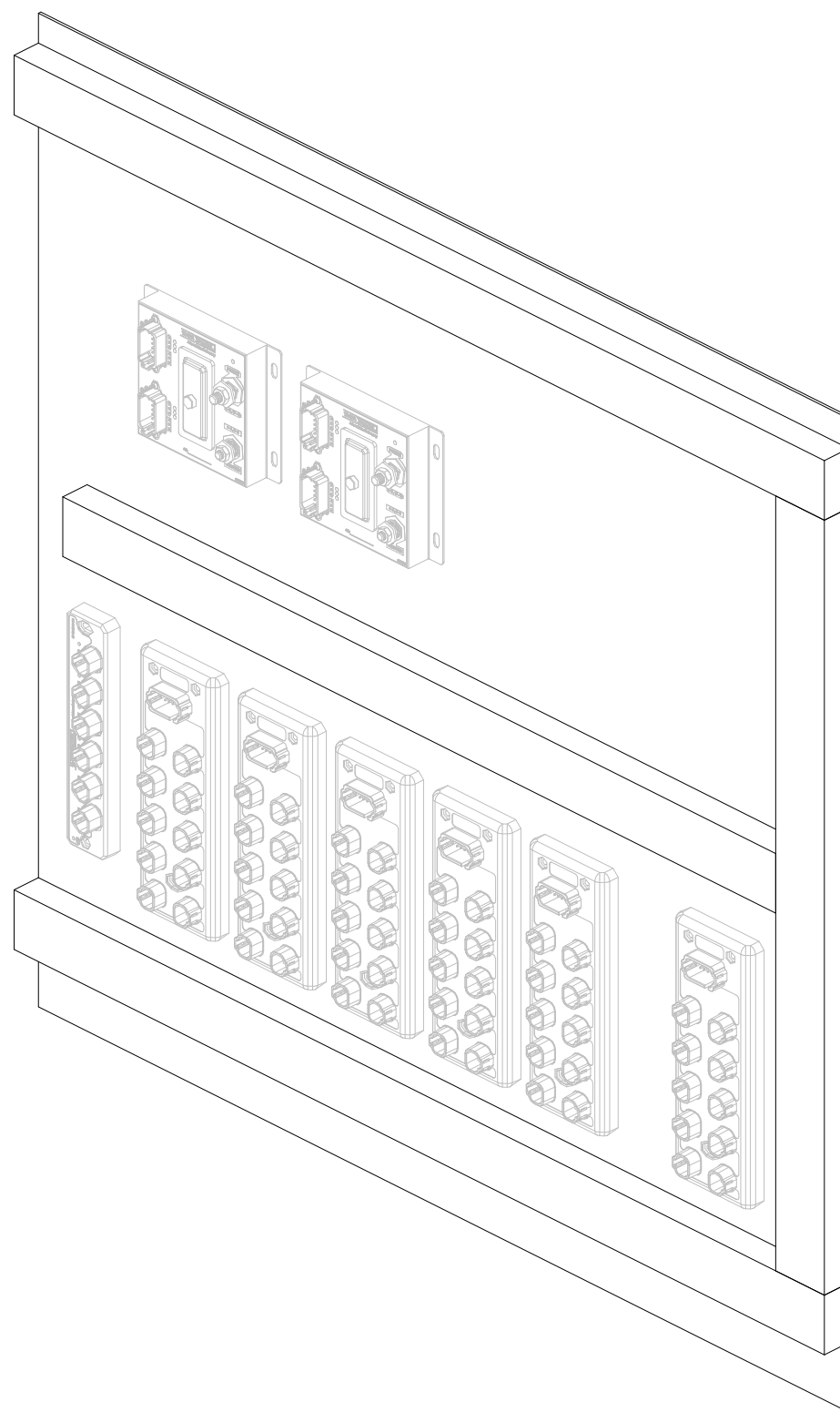

Beispiel Montageplatte
example Mounting panel

		Datum		07.02.2022	ANLAGE 1 - BEISPIEL				= UNIT1		
		Bearb.		WR	Makro Dokumentation EPLAN V2.7 - V1.2				+ MA		
		Gepr			macro Documentation EPLAN V2.7 - V1.2						
Änderung	Datum	Name	Urspr		Ersatz von	Ersetzt durch			DAPA_MUSTERPROJEKT_EPL27_V1.2		
										Blatt	1
										Blatt	30

